

**MANUAL**

**Oscilloscope  
HM 1007**

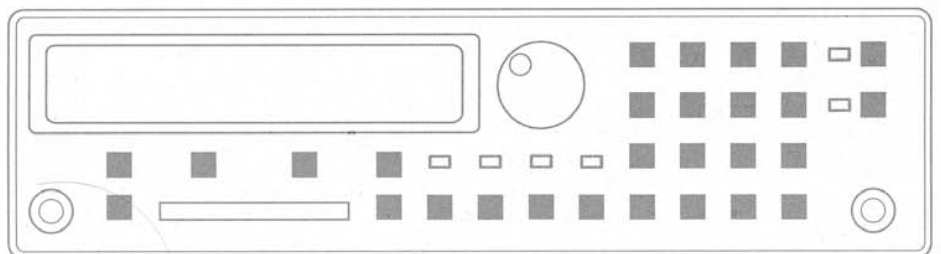
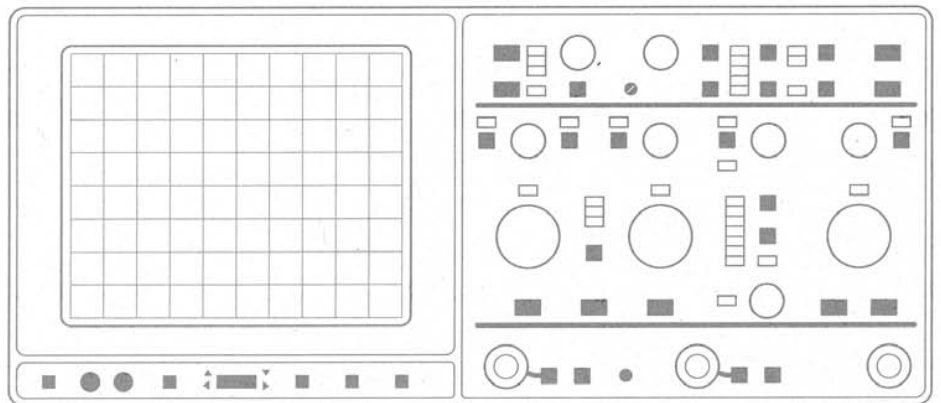

**Oscilloscope datasheet with technical details** ..... P 1

**Operating Instructions**

General Information ..... M 1  
 Use of tilt handle ..... M 1  
 Safety ..... M 1  
 Operating conditions ..... M 1  
 Warranty ..... M 2  
 Maintenance ..... M 2  
 Protective Switch-Off ..... M 2  
 Power supply ..... M 2  
 Type of signal voltage ..... M 3  
 Amplitude Measurements ..... M 3  
 Time Measurements ..... M 4  
 First Time Operation ..... M 6  
 Trace Rotation TR ..... M 6  
 Connection of Test Signal ..... M 6  
 Use and Compensation of Probes ..... M 7  
     Adjustment at 1kHz ..... M 8  
     Adjustment at 1MHz ..... M 8  
 Operating modes of the vertical amplifiers ..... M 9  
 XY Operation  
     Phase comparison with Lissajous figure ..... M10  
     Phase difference measurement in DUAL mode ..... M10  
 Measurement of an amplitude modulation ..... M11  
 Triggering and timebase  
     Automatic Peak-Triggering ..... M11  
     Normal Triggering ..... M12  
     Slope ..... M12  
     Trigger coupling ..... M15  
     Line Triggering ..... M13  
     Triggering of video signals ..... M13  
     External Triggering ..... M13  
     Trigger indicator ..... M13  
     Holdoff-time adjustment ..... M14  
     Trigge level display TLD ..... M14  
 Y Overscanning indication ..... M15  
 Scale Illumination ..... M15

**Storage mode**

Controls and indicators of the storage section and their functions ..... M15  
 Storage resolution and operating modes ..... M18  
 Maximum signal frequency in storage mode .. M18  
 Operating modes of the vertical amplifiers ..... M19  
 Protection of the memory content ..... M19  
 HAMEG Interface ..... M19  
 Safety note ..... M21

**Short instruction** ..... K 1  
     **Front Panel Elements and Folder with Front View** ..... K 2

**Important!**

Please be shure to read the safety informations on pages M1 and M21.

**Oscilloscope  
HM 1007**

**Test Instructions**

General ..... T 1  
 Cathode-Ray Tube: Brightness and Focus, Linearity, Raster Distortion ..... T 1  
 Astigmatism Check ..... T 1  
 Symmetry and Drift of the Vertical Amplifier .. T 1  
 Calibration of the Vertical Amplifier ..... T 1  
 Transmission Performance of the Vertical Amplifier ..... T 1  
 Operating Modes: CH.I/II, DUAL, ADD, CHOP., INVERT- and XY-Operation ..... T 2  
 Triggering Checks ..... T 2  
 Timebase ..... T 3  
 Trace Alignment ..... T 3

**Service Instructions**

general remarks ..... S 1  
 Safety Notes ..... S 1  
 Instrument case Removal ..... S 1  
 Operating Voltages ..... S 1

**Specifications**

**Vertical Deflection**

**Operating modes:** Channel I or Ch. II separate, Channel I and II; alternate or chopped. (Chopper frequency approx. 0.5MHz)  
**Sum or. Difference:** both channels invertable.  
**X-Y Mode:** via Channel I and Channel II  
**Frequency range (analog):** DC-100MHz (-3dB). Risettime: <3,5ns. Overshoot: ≤1%  
**Deflection coefficients:** 10 calibrated positions from 5mV/div. to 5V/div. (±3%) in 1-2-5 sequence variable 2,5:1 to min. **12,5V/div.**  
**Y-expansion x5** (calibrated) to **1mV/div.** (±5%) in the frequency range from DC - 10MHz (-3dB).  
**Input impedance:** 1MΩ II 25pF. Coupling: DC-AC-GND. Input voltage: max. 400V (DC+peak AC).  
**Delay line:** approx. 90ns

**Triggering**

With automatic (peak-to-peak): **10Hz-130MHz** (≤ 0.5div. height),  
 Normal with level control: **DC-130MHz**.  
 Threshold external: ≥100mV.  
 Slope: pos. or neg. LED for trigger indication  
 Sources: Channel I, Channel II, line, external.  
 Coupling: **AC** (10Hz-40MHz), **DC** (0-40MHz), **HF** (30Hz-130MHz), **LF** (0-2kHz)..  
**Trigger level indicator.**  
**TV-Sync-Separator**

**Horizontal Deflection**

**Time coefficients (analog):** 23 calibr. steps from 50ns to 1s/cm (±3%) in 1-2-5 sequence, variable 2,5:1 to min. 2,5s/div., with **X-expansion x10 to 5ns/div.** (±5%).  
**Hold-Off time:** variable to approx. 10:1  
**Time coefficients (digital):** 22 calibr. steps from 5µs-50ms/div. and 0,1s-50s/div. ±3%, with **X-expansion x50 to 100ns/div.** (±5%).  
**Bandwidth X-amplifier:** 0-2MHz (-3dB)  
 Input X-amplifier via Channel II, Sensitivity see Channel II.  
**X-Y-phase shift (analog):** <3° below 120kHz.  
**X-Y-phase shift (digital):** <3° below 500kHz.

**Digital Storage**

**Operating modes:** Roll, Refresh, Single, XY-Mode, Hold, Save Reference, Display Ref., **Dot Joiner**.  
**Sampling rate: max. 40MS/s per channel** (realtime).  
**Memory:** 2k x 8 bit per Channel..  
 Reference Memory: 2k x 8 bit per Channel.  
**Pretrigger:** 0 or 50%.  
**Resolution X:** 200 points/div.; **Y:** 25 points/div.; **XY:** 25x25 points/div.  
**X-expansion:** x5, x 10, and x50.  
**XY:** 2x2kx8 bit; Reference memory 2x2kx8 bit.  
 Memory back-up by two AAA-type batteries.  
 Input for external timebase clock (TTL).  
 HAMEG-Interface with bi-directional data bus for external connection of options:  
 HAMEG-Graphicprinter or -Multifunction-Interface (IEEE-Bus, RS232, Matrixprinter and XY-Recorder).

**General Information**

**CRT:** D14-372GH, **8x10div.**, approx.. 14kV.  
 Rectangular screen, internal graticule, quick-heating Graticule illumination (switchable).  
 Trace rotation adjustable on front panel.  
 Calibrator: ≈1kHz / ≈1MHz, 0.2V/2V ±1% (t, ≈ 5ns).  
**Protective standard:** IEC348; Safety Class I  
 Line voltages: 90 to 260V~  
**Power consumption:** approx. 47 Watt, 50...400Hz.  
 Max. ambient temperature: -10°C...+40°C  
 Weight: approx. 7kg. Colour: techno-brown.  
 Cabinet (mm): **W** 285, **H** 145, **D** 380.

Subject to change without notice

4.93

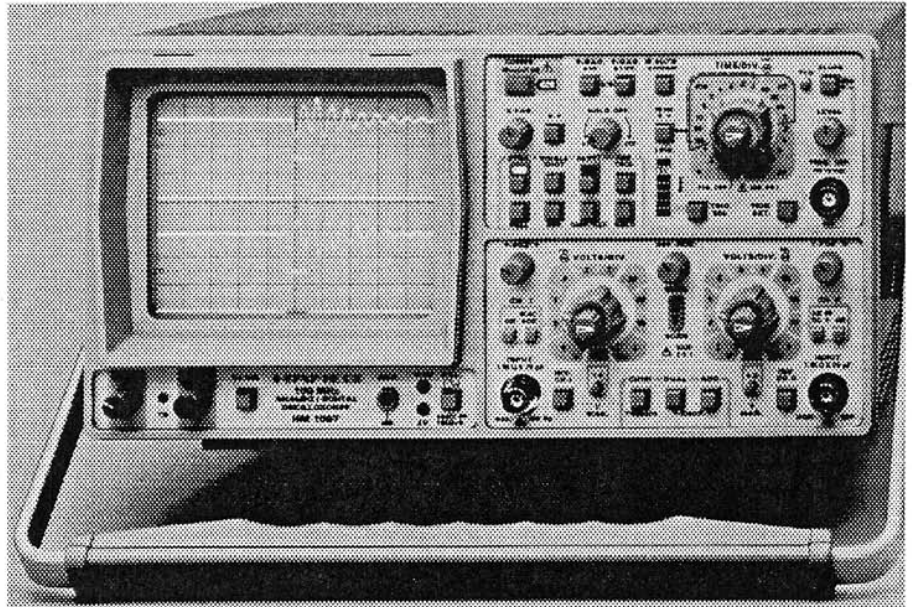

**Analog-Digital Oscilloscope HM 1007**

**Analog: 2 Channels 0-100MHz, Time base max. 5ns/div.**  
**Digital: Max. Sampling Rate 2x40MS/s, Storage 4x2048x8 bit**

With the new model **HM1007**, HAMEG again offers an analog/digital Oscilloscope with practically no competition in its price range. The **100MHz** analog bandwidth, the **40MS/s** sampling rate, **2kB** storage capacity for each channel, and a reference memory of similar size all demonstrate the high performance engineering embodied in the **HM1007**. A special feature is the **Trigger Level Display** which allows precise adjustment of trigger level for the capture and display of single events.

The digital section of the **HM1007** is based on a "state-machine" concept. One of the instrument's main advantages is the fact that the entire internal control is fully synchronized. Data acquisition is possible in **Refresh, Roll, Single** and **XY**-mode. An data entered into the main memory can be compared with reference signals at any given time. The Y-position of the reference signal(s) can be moved vertically to allow exact comparison with the current signal(s). **Pre-trigger** can be activated to obtain "pre history" information on a transient event. Time base in digital mode is expandable to maximum of **50 times** with a resolution of **4 points/div.** This means that, with resolution of 40 points, a **1MHz** signal can be expanded to fill the entire screen, providing enhanced signal recognition through the **"Dot-Joiner"** feature. Two batteries prevent data-loss in case of power failure. With the optional Interface **HO79**, including software the **HM1007** can be connected to any XT/AT compatible computer. Thus data can also be transferred via IEEE-488 or RS232 to the HM1007 memory. Another available option is the use of the HAMEG graphics printer **HD148**.

The analog portion of the instrument is equally well designed. Each of the two channels has **100MHz** bandwidth. The **delay line** allows the display of the leading edge of waveforms. The transient response over the entire signal path, from probe tip to CRT, can be easily and precisely monitored by using the built-in 1kHz / 1MHz calibrator (rise time approx. 5ns). Automatic peak-value trigger and **130MHz** trigger bandwidth ensure reliable triggering of signals as small as 0.5div. amplitude.

The positive appearance of the instrument is enhanced by the exceptionally bright and sharp **14kV** CRT which provides clear displays even in well lit environments. In operation as well as in technical detail, the **HM1007** presents itself as a practical and technically mature oscilloscope of interest to any professional.

**Accessories supplied**

Line cord, Operators Manual,  
 2 Probes 10:1 HZ51

**Optional accessories**

50Ω-feedthrough termination HZ22  
 Viewing hood HZ 47  
 Carrying case HZ96  
 Multifunction-Bus HO79

# Operating Instructions

## General Information

The HM1007 is the combination of an analog 100MHz oscilloscope and a digital storage oscilloscope.

This oscilloscope is easy to operate. The logical arrangement of the controls allows anyone to become familiar with the operation of the instrument after a short time, however, experienced users are also advised to read through these instructions so that all functions are understood.

Immediately after unpacking, the instrument should be checked for mechanical damage and loose parts in the interior. If there is transport damage, the supplier must be informed immediately. The instrument must not then be put into operation.

## Use of tilt handle

To view the screen from the best angle, there are three different positions (C, D, E) for setting up the instrument. If the instrument is set down on the floor after being carried, the handle automatically remains in the upright carrying position (A).

In order to place the instrument onto a horizontal surface, the handle should be turned to the upper side of the oscilloscope (C). For the D position (10° inclination), the handle should be turned in the opposite direction out of the carrying position until it locks in place automatically underneath the instrument. For the E position (20° inclination), the handle should be pulled to release it from the D position and swing backwards until it locks once more.

The handle may also be set to a position for horizontal carrying by turning it to the upper side to lock in the B position. At the same time, the instrument must be lifted, because otherwise the handle will jump back.

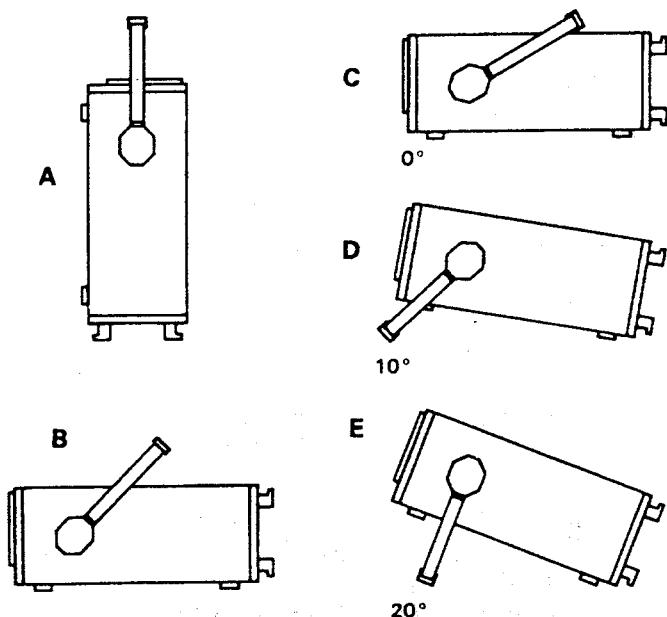

## Safety

### Warning!

The following safety information applies only if the interface on the rear panel of the oscilloscope is not used. **Prior to using the interface, the additional safety information on page M 21 must be read and observed.**

This instrument has been designed and tested in accordance with **IEC Publication 348, Safety Requirements for Electronic Measuring Apparatus**. The CENELEC HD401 regulations correspond to this standard. It has left the factory in a safe condition. The present instruction manual contains important information and warnings which have to be followed by the user to ensure safe operation and to retain the oscilloscope in safe condition. **The case, chassis and all measuring terminal: are connected to the protective earth contact of the appliance inlet.** The instrument operates according to **Safety Class I** (three-conductor power cord with protective earthing conductor and a plug with earthing contact). The mains/line plug should only be inserted in a socket outlet provided with a protective earth contact. The protective action must not be negated by the use of an extension cord without a protective conductor.

**The mains/line plug should be inserted before connections are made to measuring circuits.**

The grounded accessible metal parts (case, sockets, jacks and the mains/line supply contacts (line/live, neutral) of the instrument have been tested against insulation breakdown with **2200V DC**.

Under certain conditions, 50Hz or 60Hz hum voltages can occur in the measuring circuit due to the interconnection with other mains/line powered equipment or instruments. This can be avoided by using an isolation transformer (Safety Class II) between the mains/line outlet and the power plug of the device being investigated.

Most cathode-ray tubes develop X-rays. However, the dose equivalent rate falls **far below the maximum permissible value of 36pA/kg** (0.5mR/h).

Whenever it is likely that protection has been impaired the instrument shall be made inoperative and be secured against any unintended operation. The protection is likely to be impaired if, for example, the instrument

- shows visible damage,
- fails to perform the intended measurements,
- has been subjected to prolonged storage under unfavourable conditions (e.g. in the open or in moist environments),
- has been subject to severe transport stress (e.g. in poor packaging).

## Operating conditions

The instrument has been designed for indoor use. The permissible ambient temperature range during operation is +10°C (+50°F) ... +40°C (+104°F). It ma

occasionally be subjected to temperatures between +10°C (+50°F) and -10°C (+14°F) without degrading its safety. The permissible ambient temperature range for storage or transportation is -40°C (-40°F) ... +70°C (+158°F).

The maximum operating altitude is up to 2200m (non-operating 15000m). The maximum relative humidity is up to 80%.

If condensed water exists in the instrument it should be acclimatized before switching on. In some cases (e.g. extremely cold oscilloscope) two hours should be allowed before the instrument is put into operation. The instrument should be kept in a clean and dry room and must not be operated in explosive, corrosive, dusty, or moist environments. The oscilloscope can be operated in any position, but the convection cooling must not be impaired. The ventilation holes may not be covered. For continuous operation the instrument should be used in the horizontal position, preferably tilted upwards, resting on the tilt handle.

**The stated specification tolerances are only valid if the instrument has warmed up for 30 minutes at an ambient temperature between +15°C (+59°F) and +30°C (+86°F). Values without tolerances are typical for an average instrument.**

### Warranty

HAMEG warrants to its Customers that the products that it manufactures and sells will be free from defects in materials and workmanship for a **period of 2 years**. This warranty shall not apply to any defect, failure or damage caused by improper use or inadequate maintenance and care. HAMEG shall not be obliged to provide service under this warranty to repair damage resulting from attempts by personnel other than HAMEG representatives to install, repair, service or modify these products. In order to obtain service under this warranty, Customers must contact and notify the distributor who has sold the product.

Each instrument is subjected to a quality test with 10 hour burn-in before leaving the production. Practically all early failures are detected by this method. However, it is possible that a component may fail only after a lengthy operating period. In the case of shipments by post, rail or carrier it is recommended that the original packing is carefully preserved. Transport damage and damage due to gross negligence are not covered by the guarantee.

In the case of a complaint, a label should be attached to the housing of the instrument which describes briefly the faults observed. If at the same time the name and telephone number (dialing code and telephone or direct number or department designation) is stated for possible queries, this helps towards speeding up the processing of guarantee claims.

### Maintenance

Various important properties of the oscilloscope should be carefully checked at certain intervals. Only in this way is it largely certain that all signals are displayed with the accuracy on which the technical data are based. The test methods described in the test plan of this manual can be performed without great expenditure on measuring instruments. However, purchase of the new HAMEG **SCOPE TESTER HZ 60**, which despite its low price is highly suitable for tasks of this type, is very much recommended.

The exterior of the oscilloscope should be cleaned regularly with a dusting brush. Dirt which is difficult to remove on the casing and handle, the plastic and aluminium parts, can be removed with a moistened cloth (99% water + 1% mild detergent). Spirit or washing benzene (petroleum ether) can be used to remove greasy dirt. The screen may be cleaned with water or washing benzene (but not with spirit (alcohol) or solvents), it must then be wiped with a dry clean lint-free cloth. Under no circumstances may the cleaning fluid get into the instrument. The use of other cleaning agents can attack the plastic and paint surfaces.

### Protective Switch-Off

This instrument is equipped with a switch mode power supply. It has both overvoltage and overload protection, which will cause the switch mode supply to be disabled. Disruptions or distortion on the mains/line supply may also cause the protective circuit to activate. The **POWER** button should be switched off and a minimum 10 second delay is required before the **POWER** button should be depressed to switch on.

### Power supply

The oscilloscope operates on line voltages between 100V and 240V<sub>AC</sub>. No means of switching to different input voltages has therefore been provided.

The power input fuses are externally accessible. The fuseholders are located above the 3-pole power connector. Never attempt to replace a fuse without first disconnecting the power cord. A screwdriver must be used to unscrew the fuse holder. The fuse can then be replaced and the holder screwed in.

Use of patched fuses or short-circuiting of the fuseholder is not permissible; HAMEG assumes no liability whatsoever for any damage caused as a result, and all warranty claims become null and void.

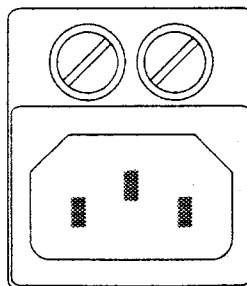

### Fuse type:

size **5 mm x 20 mm**,  
**1A**, 250-volt AC fuse;  
must meet IEC specification  
127 sheet III (or DIN 41 662 or  
DIN 41 571, sheet 3).  
Time characteristic: **time-lag**.

## Type of signal voltage

With the HM 1007, most repetitive signals in the frequency range up to at least **100MHz** can be examined in the analog mode.

However when examining square or pulse type waveforms, attention must be paid to the harmonic content of such signals. The repetition frequency (fundamental frequency) of the signal must therefore be significantly smaller than the upper limit frequency of the vertical amplifier.

Displaying composite signals can be difficult, especially if they contain no repetitive higher amplitude content which can be used for triggering. This is the case with bursts, for instance. To obtain a well-triggered display in this case, the assistance of the variable holdoff and/or variable time control may be required. Television video signals are relatively easy to trigger using the built-in TV-Sync-Separator (TV).

In the digital storage mode, other factors such as signal shape and screen display size will also cause limitations due to the digital sampling rate. The display and storage of low and mid frequency sinewave voltages is straight forward.

For optional operation as a DC or AC voltage amplifier, the vertical amplifier input is provided with a DC/AC switch. The DC position should only be used with a series-connected attenuator probe or at very low frequencies or if the measurement of the DC voltage content of the signal is absolutely necessary.

When displaying very low frequency pulses, the flat tops may be sloping with AC coupling of the vertical amplifier (AC limit frequency approx. 3Hz for 3dB). In this case, DC operation is preferred, provided the signal voltage is not superimposed on a too high DC level. Otherwise a capacitor of adequate capacitance must be connected to the input of the vertical amplifier with DC coupling. This capacitor must have a sufficiently high breakdown voltage rating. DC coupling is also recommended for the display of logic and pulse signals, especially if the pulse duty factor changes continuously. Otherwise the display will move upwards or downwards at each change. Pure direct voltages can only be measured with DC coupling.

## Amplitude Measurements

In general electrical engineering, alternating voltage data normally refers to effective values (rms = root-mean-square value). However, for signal magnitudes and voltage designations in oscilloscope measurements, the peak-to-peak voltage ( $V_{pp}$ ) value is applied. The latter corresponds to the real potential difference between the most positive and most negative points of a signal waveform.

If a sinusoidal waveform, displayed on the oscilloscope

screen, is to be converted into an effective (rms) value, the resulting peak-to-peak value must be divided by  $2\sqrt{2} = 2.83$ . Conversely, it should be observed that sinusoidal voltages indicated in  $V_{rms}$  ( $V_{eff}$ ) have 2.83 times the potential difference in  $V_{pp}$ . The relationship between the different voltage magnitudes can be seen from the following figure.

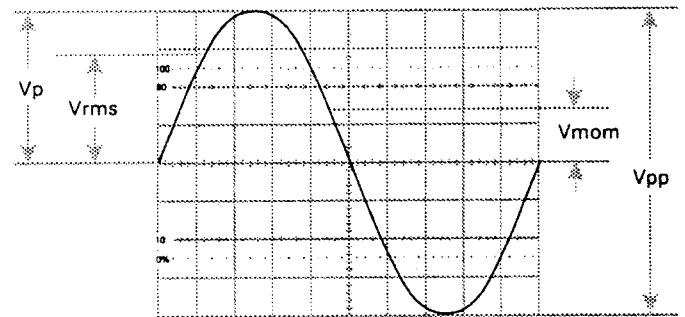

### Voltage values of a sine curve

$V_{rms}$  = effective value;  $V_p$  = simple peak or crest value;  
 $V_{pp}$  = peak-to-peak value;  $V_{mom}$  = momentary value.

The minimum signal voltage which must be applied to the Y input for a trace of 1 div. height is **1mV<sub>pp</sub>** when the **Y MAG.x5** pushbutton is depressed, the VOLTS/DIV. switch is set to **5mV/div.**, and the vernier is set to **CAL** by turning the **fine adjustment knob** of the VOLTS/DIV. switch clockwise all the way. However, smaller signals than this may also be displayed. The deflection coefficients on the input attenuators are indicated in mV/div. or V/div. (peak-to-peak value).

**The magnitude of the applied voltage is ascertained by multiplying the selected deflection coefficient by the vertical display height in div.**

If an attenuator probe x10 is used, a further multiplication by a factor of 10 is required to ascertain the correct voltage value.

**For exact amplitude measurements, the variable control on the attenuator switch must be set to its calibrated detent CAL.** When turning the variable control ccw, the sensitivity will be reduced by a factor of at least 2.5. Therefore every intermediate value is possible within the 1-2-5 sequence.

With direct connection to the vertical input, **signals up to 100V<sub>pp</sub>** may be displayed (attenuator set to **5V/div.**, variable control to left stop).

With the designations

**H**= display height in div.,

**U**= signal voltage in V<sub>pp</sub> at the vertical input,

**D**= deflection coefficient in V/div. (attenuator switch),

the required value can be calculated from the two known values:

$$U = D \cdot H$$

$$H = \frac{U}{D}$$

$$D = \frac{U}{H}$$

**However, these three values must be confined within the following limits (trigger threshold, accuracy of reading):**



**H** between 0.5 and 8 div., the accuracy of reading increases with the signal height,  
**U** between 1mV<sub>pp</sub> and 40V<sub>pp</sub>,  
**D** between 1mV/div. and 5V/div. in 1-2-5 sequence.

**Examples:**

Set deflection coefficient **D** = 50mV/div.  $\Delta$  0.05 V/div.,  
observed display height **H** = 4.6 div.,  
**required voltage U** = 0.05x4.6 = **0.23V<sub>pp</sub>**.

Input voltage **U** = 5V<sub>pp</sub>,  
set deflection coefficient **D** = 1V/div.,  
**required display height H** = 5:1 = **5div.**

Signal voltage **U** = 220V<sub>rms</sub> x 2x $\sqrt{2}$  = 622 V<sub>pp</sub>  
(voltage >40V<sub>pp</sub>, with probe x100: **U** = 6.22 V<sub>pp</sub>),  
desired display height **H** = min. 3.2div., max. 8div.,  
max. deflection coefficient **D** = 6.22:3.2 = 1.94V/div.,  
min. deflection coefficient **D** = 6.22:8 = 0.78V/div.,  
**adjusted deflection coefficient D** = 1V/div.

**If the applied signal is superimposed on a DC (direct voltage) level the total value (DC + peak value of the alternating voltage) of the signal at the Y-input must not exceed  $\pm 400V$**  (see figure).

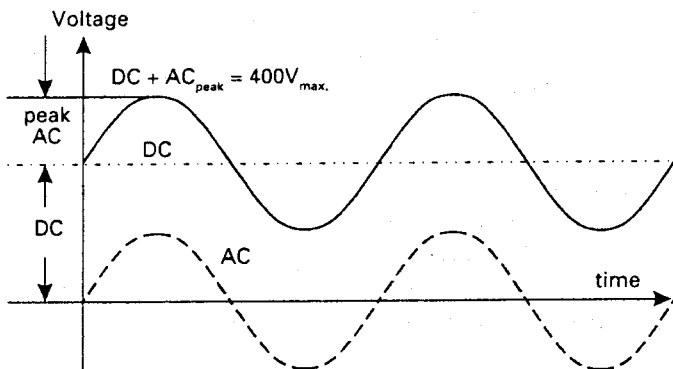

**Total value of input voltage**

The dotted line shows a voltage alternating at zero volt level. When superimposed on a DC level, the addition of the positive peak and the DC voltage results in the max. voltage (DC + ACpeak)

This same limit applies to normal x10 attenuator probes, the attenuation ratio of which allows signal voltages up to approximately 400V<sub>pp</sub> to be evaluated. Voltages of up to approximately 2,400V<sub>pp</sub> may be measured by using the HZ53 high voltage probe which has an attenuation ratio of 100:1. It should be noted that its ACpeak value is derated at higher frequencies. If a normal x10 probe is used to measure high voltages, there is the risk that the compensation trimmer bridging the attenuator series resistor will break down, causing damage to the input of the oscilloscope. However, if for example only the residual ripple of a high voltage is to be displayed on the oscilloscope, a normal x10 probe is sufficient. In this case, an appropriate high voltage capacitor (approx. 22-68nF) must be connected in series with the input tip of the probe.

It is very important that the oscilloscope input coupling is set to **DC**, if an attenuator probe is used for voltages higher than 400V (see page M6: Connection of Test Signal).

With **Y-POS.** control (input coupling to **GD**) it is possible to use a horizontal graticule line as **reference line for ground potential** before the measurement. It can lie below or above the horizontal centre line according to whether positive and/or negative deviations from the ground potential are to be measured. Certain switchable x10/x1 attenuator probes also have a built-in ground reference switch position.

**Time Measurements**

As a rule, most signals to be displayed are periodically repeating processes. The number of periods per second is the repetition frequency. Depending on the timebase setting of the **TIME/DIV.** switch, one or several signal periods, or only a part of a period can be displayed. The time coefficients are stated in **s/div.**, **ms/div.** and  **$\mu$ s/div.** on the **TIME/DIV.**-switch. The scale is accordingly divided into fields.

There are 23 time coefficient ranges in the analog mode of the HM1007, from 0.05 $\mu$ s/div. to 1s/div..

The Continuous or dashed black lines traced round the scale have no significance in the analog mode of the oscilloscope. The pushbutton ms/s to the left of the scale also has no function in this case. It is required only in the digital memory mode.

**The duration of a signal period or a part of it is determined by multiplying the relevant time (horizontal distance in div.) by the time coefficient set on the TIME/DIV.-switch.**

The variable time control (identified with an arrow knob cap) must be in its calibrated position CAL. (arrow pointing horizontally to the right). **This variable control is inoperative in the storage mode.**

With the designations

- L** = displayed wave length in div. of one period,
- T** = time in seconds for one period,
- F** = recurrence frequency in Hz of the signal,
- Tc** = time coefficient in s/div. on timebase switch and the relation **F = 1/T**, the following equations can be stated:

$$T = L \cdot Tc \qquad L = \frac{T}{Tc} \qquad Tc = \frac{T}{L}$$

$$F = \frac{1}{L \cdot Tc} \qquad L = \frac{1}{F \cdot Tc} \qquad Tc = \frac{1}{L \cdot F}$$

**With depressed X-MAG. x10 pushbutton the Tc value must be divided by 10.**

However, these four values are not unconditionally selectable. They have to be within the following limits:

- L** between 0.2 and 10div., if possible 4 to 10div.,
- T** between 0.05 $\mu$ s and 500s,
- F** between 1mHz and 100MHz,
- Tc** between 0.05 $\mu$ s/div. and 50s/div. in 1-2-5 sequence (with **X-MAG. x10 in out position**), and
- Tc** between 5ns/div. and 5s/div. in 1-2-5 sequence (with **pushed X-MAG. x10 pushbutton**).

**Examples:**

Displayed wavelength **L** = 7div.,  
 set time coefficient **Tc** = 0.05 $\mu$ s/div.,  
**required period T** =  $7 \times 0.05 \times 10^{-6} = 0.35\mu$ s  
**required rec. freq. F** =  $1 : (0.35 \times 10^{-6}) = 2.86\text{MHz}$ .

Signal period **T** = 0.5s,  
 set time coefficient **Tc** = 0.2s/div.,  
**required wavelength L** =  $0.5 : 0.2 = 2.5\text{div.}$ .

Displayed ripple wavelength **L** = 1div.,  
 set time coefficient **Tc** = 10ms/div.,  
**required ripple freq. F** =  $1 : (1 \times 10 \times 10^{-3}) = 100\text{Hz}$ .

TV-line frequency **F** = 15 625Hz,  
 set time coefficient **Tc** = 10 $\mu$ s/div.,  
**required wavelength L** =  $1 : (15\ 625 \times 10^{-5}) = 6.4\text{div.}$

Sine wavelength **L** = min. 4div., max. 10div.,  
 Frequency **F** = 1kHz,  
 max. time coefficient **Tc** =  $1 : (4 \times 10^3) = 0.25\text{ms/div.}$ ,  
 min. time coefficient **Tc** =  $1 : (10 \times 10^3) = 0.1\text{ms/div.}$ ,  
**set time coefficient Tc = 0.2ms/div.**,  
**required wavelength L** =  $1 : (10^3 \times 0.2 \times 10^3) = 5\text{div.}$

Displayed wavelength **L** = 0.8div.,  
 set time coefficient **Tc** = 0.5 $\mu$ s/div.,  
**pressed X-MAG. x10 button: Tc** = 0.05 $\mu$ s/div.,  
**required rec. freq. F** =  $1 : (0.8 \times 0.05 \times 10^6) = 25\text{MHz}$ ,  
**required period T** =  $1 : (25 \times 10^6) = 40\text{ns}$ .

If the time is relatively short as compared with the complete signal period, an expanded time scale should always be applied (**X-MAG. x10** button pressed). In this case, the measured time values have to be divided by 10. The time interval of interest can be shifted to the screen center using the **X-POS.** control.

When investigating pulse or square waveforms, the critical feature is the risetime of the voltage step. To ensure that transients, ramp-offs, and bandwidth limits do not unduly influence the measuring accuracy, the risetime is generally measured between **10%** and **90%** of the vertical pulse height. For peak-to-peak signal amplitudes of **5div.** height, which are symmetrically adjusted to the horizontal center line, the internal graticule of the CRT has two horizontal

dotted lines  $\pm 2.5\text{div.}$  from the center line. Adjust the Y attenuator switch with its variable control together with the Y-POS. control so that the pulse height is precisely aligned with these 0 and 100% lines. The 10% and 90% points of the signal will now coincide with the two lines, which have a distance of 2div. from the horizontal center line and an additional subdivision of 0.2div.. The risetime is given by the product of the horizontal distance in div. between these two coincidence points and the time coefficient setting. If magnification is used, this product must be divided by 10. The fall time of a pulse can also be measured by using this method.

The following figure shows correct positioning of the oscilloscope trace for accurate risetime measurement.

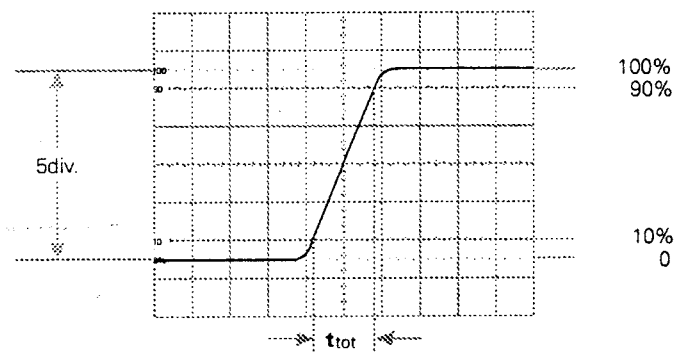

With a time coefficient of 0.05 $\mu$ s/div. and pushed X-MAG x10 button the example shown in the above figure results in a measured total risetime of

$$t_{\text{tot}} = 1.6\text{div.} \times 0.05\mu\text{s/div.} : 10 = 8\text{ns}$$

When very fast risetimes are being measured, the risetimes of the oscilloscope amplifier and of the attenuator probe has to be deducted from the measured time value. The risetime of the signal can be calculated using the following formula.

$$t_r = \sqrt{t_{\text{tot}}^2 - t_{\text{osc}}^2 - t_p^2}$$

In this  $t_{\text{tot}}$  is the total measured risetime,  $t_{\text{osc}}$  is the risetime of the oscilloscope amplifier (approx. 3.5ns), and  $t_p$  the risetime of the probe (e.g. = 2ns). If  $t_{\text{tot}}$  is greater than 34ns, then  $t_{\text{tot}}$  can be taken as the risetime of the pulse, and calculation is unnecessary.

Calculation of the example in the figure above results in a signal risetime

$$t_r = \sqrt{8^2 - 3.5^2 - 2^2} = 6.91\text{ns}$$

The measurement of the rise or fall time is not limited to the trace dimensions shown in the above diagram. It is only particularly simple in this way. In principle it is possible to measure in any display position and at any signal amplitude. It is only important that the full height of the signal edge of interest is visible in its full length at not too great steepness and that the horizontal distance at 10% and 90% of the amplitude is measured. If the edge shows rounding or overshooting, the 100% should not be related



to the peak values but to the mean pulse heights. Breaks or peaks (glitches) next to the edge are also not taken into account. With very severe transient distortions, the rise and fall time measurement has little sense. For amplifiers with approximately constant group delay (therefore good pulse transmission performance) the following numerical relationship between rise time  $t_r$  (in ns) and bandwidth **B** (in MHz) applies:

$$t_r = \frac{350}{B} \quad B = \frac{350}{t_r}$$

## First Time Operation

Before applying power to the oscilloscope it is recommended that the following simple procedures are performed:

Check that all pushbuttons except **GD** are in the out position, i.e. released.

Both **GD** switches for CH.I and CH.II in the Y-field should be set to the GD position (depressed).

Check that **HOLD OFF** is in **x1** position.

Rotate the three variable controls, i.e. **TIME/DIV.** variable control, CH.I and CH.II attenuator variable controls to their calibrated detents.

Set all controls with marker lines to their midrange position (marker lines pointing vertically).

Switch on the oscilloscope by depressing the red **POWER** pushbutton. An LED will illuminate to indicate working order. The trace, displaying one baseline, should be visible after a short warm-up period of 10 seconds. Adjust Y-POS.I and X-POS. controls to center the baseline. Adjust **INTENS.** (intensity) and **FOCUS** controls for medium brightness and optimum sharpness of the trace. The oscilloscope is now ready for use.

If only a spot appears (**CAUTION!** CRT phosphor can be damaged.), reduce the intensity immediately and check that the X-Y pushbutton is in the released (out) position. If the trace is not visible, check the correct positions of all knobs and switches (particularly **AUTO/NORM** pushbutton in).

To obtain the maximum life from the cathode-ray tube, the minimum intensity setting necessary for the measurement in hand and the ambient light conditions should be used.

Particular care is required when a single spot is displayed, as a very high intensity setting may cause damage to the fluorescent screen of the CRT. Switching the oscilloscope off and on at short intervals stresses the cathode of the CRT and should therefore be avoided. Please note that after switching off a minimum waiting time of 10 seconds is required until the instrument can be switched on again.

The instrument is so designed that even incorrect operation will not cause serious damage. The pushbuttons control

only minor functions, and it is recommended that before commencement of operation all pushbuttons are in the "out" position. After this the pushbuttons can be operated depending upon the mode of operation required.

The HM1007 accepts all signals from DC (direct voltage) up to a frequency of at least **100MHz** (-3dB). For sinewave voltages the upper frequency limit will be 130-150MHz. However, in this higher frequency range the vertical display height on the screen is limited to approx. 4-5div. The time resolution poses no problem. For example, with 100MHz and the fastest adjustable sweep rate (5ns/div.), one cycle will be displayed every 2div. The tolerance on indicated values amounts to  $\pm 3\%$  in both deflection directions. All values to be measured can therefore be determined relatively accurately. However, from approximately **40MHz** upwards the measuring error will increase as a result of loss of gain. At **60MHz** this reduction is about 10%. Thus, approximately 11% should be added to the measured voltage at this frequency. As the bandwidth (-3dB) of the amplifiers differ (normally between 115 and 125MHz), the measured values in the upper limit range cannot be defined exactly. Additionally, as already mentioned, for frequencies above 100MHz the dynamic range of the display height steadily decreases. The vertical amplifier is designed so that the transmission performance is not affected by its own overshoot.

## Trace Rotation TR

***In spite of Mumetal-shielding of the CRT, the effects of the earths magnetic field on the horizontal trace position cannot be completely avoided. This is dependent upon the orientation of the oscilloscope on the place of work. A centred trace may not align exactly with the horizontal center line of the graticule. A few degrees of misalignment can be corrected by a potentiometer accessible through an opening on the front panel and marked TR.***

## Connection of Test Signal

**Caution:** When connecting unknown signals to the oscilloscope input, always use automatic triggering and set the DC-AC input coupling switch to **AC**. The attenuator switch should initially be set to **5V/div**.

Sometimes the trace will disappear after an input signal has been applied (**OVERSCAN**). The attenuator switch must then be turned back to the left, until the vertical signal height is only 3-8div. With a signal amplitude greater than **40V<sub>pp</sub>**, an attenuator probe must be inserted before the oscilloscope's vertical input. If, after applying the signal, the trace is very dim, the period of the signal is probably substantially longer than the set value on the **TIME/DIV.** switch. It should be turned to the left to an adequately larger time coefficient.

The signal to be displayed can be connected directly to the Y-input of the oscilloscope with a shielded test cable such as HZ32 and HZ34 or attenuated through a x10 or x100 attenuator probe. The use of test cables with high impedance circuits is only recommended for relatively low frequencies (up to approx. 50kHz). For higher frequencies, the signal source must be of low impedance, i.e. matched to the characteristic resistance of the cable (as a rule 50Ω). Particularly when transmitting square and pulse signals, a resistor equal to the characteristic impedance of the cable must also be connected across the cable directly at the Y-input of the oscilloscope. When using a 50Ω cable such as the HZ34, a 50Ω through termination type **HZ22** is available from HAMEG. When transmitting square signals with short rise times, transient phenomena on the edges and top of the signal may become visible if the correct termination is not used. A terminating resistance is sometimes recommended with sine signals as well. Certain amplifiers, generators or their attenuators maintain the nominal output voltage independent of frequency only if their connection cable is terminated with the prescribed resistance. Here it must be noted that the terminating resistor HZ22 will only dissipate a maximum of 2 Watts. This power is reached with  $10V_{rms}$  or - at  $28.3V_{pp}$  with sine signal.

If a x10 or x100 attenuator probe is used, no termination is necessary. In this case, the connecting cable is matched directly to the high impedance input of the oscilloscope. When using attenuator probes, even high internal impedance sources are only slightly loaded (approx.  $10M\Omega \parallel 16pF$  or  $100M\Omega \parallel 9pF$  with HZ 53). Therefore, if the voltage loss due to the attenuation of the probe can be compensated by a higher amplitude setting, the probe should always be used. The series impedance of the probe provides a certain amount of protection for the input of the vertical amplifier. Because of their separate manufacture, all attenuator probes are only partially compensated, therefore accurate compensation must be performed on the oscilloscope (see "Probe compensation page M8) each time the probe is fitted or transferred.

Standard attenuator probes on the oscilloscope normally reduce its bandwidth and increase the rise time. In all cases where the oscilloscope bandwidth must be fully utilized (e.g. for pulses with steep edges) we strongly advise using the **modular probes HZ 51** (x10) **HZ 52** (x10 HF) or **HZ 54** respectively (see oscilloscope accessories). This can save the purchase of an oscilloscope with larger bandwidth and has the advantage that defective components can be ordered from HAMEG and replaced by oneself. The probes mentioned have a HF-calibration in addition to low frequency calibration adjustment. Thus a group delay correction to the upper limit frequency of the oscilloscope is possible with the aid of a square-wave calibrator, switched to 1 MHz, e.g. HAMEG Scope Tester HZ60. In fact the bandwidth and rise time of the oscilloscope

are not noticeably reduced with these probe types and the waveform reproduction fidelity can even be improved because the probe can be matched to the oscilloscope's individual pulse response.

**If a x10 or x100 attenuator probe is used, DC input coupling must always be used at voltages above 400V.** With **AC** coupling of low frequency signals, the attenuation is no longer independent of frequency, and pulses can show pulse tilts. Direct voltages are suppressed but load the oscilloscope input coupling capacitor concerned. Its voltage rating is max. 400 V (DC + peak AC). The **DC** input coupling is therefore of quite special importance with a x100 attenuation probe which usually has a voltage rating of max. 1200 V (DC + peak AC). A **capacitor** of corresponding capacitance and voltage rating may be connected in series with the **attenuator probe input** for blocking DC voltage (e.g. for hum voltage measurement).

With all attenuator probes, the maximum **AC input voltage** must be **derated with frequency** usually above 20 kHz. Therefore the derating curve of the attenuator probe type concerned must be taken into account.

The selection of the ground point on the test object is important when displaying small signal voltages. It should always be as close as possible to the measuring point. If this is not done, serious signal distortion may result from spurious currents through the ground leads or chassis parts. The ground leads on attenuator probes are also particularly critical. They should be as short and thick as possible. When the attenuator probe-tip is connected to a BNC-socket, a BNC-adaptor, which is often supplied as probe accessory, should be used. In this way ground and matching problems are eliminated.

Hum or interference appearing in the measuring circuit is often caused by multiple grounding because equalizing currents can flow in the shielding of the test cables (voltage drop between the protective conductor connections, caused by external equipment connected to the mains/line, e.g. signal generators with interference protection capacitors). This is particularly noticeable when a small deflection coefficient is used.

## Use and Compensation of Probes

To display an undistorted waveform on an oscilloscope, the probe must be matched to the individual input impedance of the vertical amplifier.

The HM1007s built-in calibration generator provides a squarewave signal with a very low risetime (<5ns), and switch-selectable frequencies of approx. 1kHz and 1MHz from two output sockets below the CRT screen.

**THIS SIGNAL SHOULD NOT BE USED FOR FREQUENCY CALIBRATION.**

One output provides  $0.2V_{pp} \pm 1\%$  for 10:1 probes, and  $2V_{pp} \pm 1\%$  are present at the other, for 100:1 probes.

When the attenuator switches are set to  $5mV/div$  vertical deflection coefficient, these calibration voltages correspond to a **screen amplitude of 4div**.

The output sockets have an internal diameter of 4.9mm to accommodate the internationally accepted shielding tube diameter of modern **Modular Probes** and **F-series** slimline probes. Only this type of construction ensures the extremely short ground connections which are essential for an undistorted waveform reproduction of non-sinusoidal high frequency signals.

### Adjustment at 1kHz

The C-trimmer adjustment compensates the capacitive loading on the oscilloscope input (approx. 25pF with the HM1007). By this adjustment, the capacitive division assumes the same division ratio as the ohmic voltage divider to ensure an equal division ratio for high and low frequencies, as for DC. (For 1:1 probes or switchable probes set to 1:1, this adjustment is neither required nor possible). A baseline exactly parallel to the horizontal graticule lines is a major condition for accurate probe adjustments. (See also Trace Rotation TR)

Connect the probes (Types HZ51, 52, 53, 54, or HZ36) to **CH.I** input. All pushbuttons should be released (in the out position). Set the input coupling switch to **DC**, the attenuator switch to  $5mV/div$ , and the **TIME/DIV.** switch to  $0.2ms/div$ , and all variable controls to **CAL.** position. Plug the probe tip into the appropriate calibrator output socket, i.e. 10:1 probes into the  $0.2V$  socket, 100:1 probes into the  $2.0V$  socket.

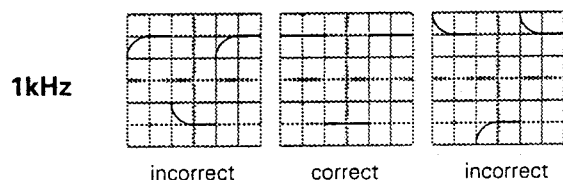

Approximately 2 complete waveform periods are displayed on the CRT screen. Now the compensation trimmer has to be adjusted. Normally, this trimmer is located in the probe head. On the 100:1 probe HZ53, however, it is located in the connecting box at the other end of the cable. Using a small insulated non-metallic screwdriver or trimming tool, the trimmer has to be adjusted slowly until the tops of the squarewave signal are exactly parallel to the horizontal graticule lines. (See Fig. above for 1kHz.) The signal amplitude shown should be  $4cm \pm 1.2mm (= 3\%)$ . During this adjustment, the signal edges will remain invisible.

### Adjustment at 1MHz

Probes HZ51, 52 and 54 will also allow for HF-adjustments. They incorporate resonance deemphasizing networks (R-trimmer in conjunction with inductances and capacitors) which permit for the first time probe compensation in the

range of the upper frequency limit of the vertical oscilloscope amplifier. Only this compensative adjustment ensures optimum utilisation of the full bandwidth, together with constant group delay at the high frequency end, thereby reducing characteristic transient distortion near the leading signal edge (e.g. overshoot, rounding, ringing, holes or bumps) to an absolute minimum.

Using the probes HZ51, 52, and 54, the full bandwidth of the HM1007 can be utilized without risk of unwanted waveform distortion.

Prerequisite for this HF-adjustment is a squarewave generator with fast risetime (typical 4ns), and low output impedance (approx.  $50\Omega$ ), providing 0.2V and 2V at a frequency of approx. 1MHz. The calibrator output of the HM1007 meets these requirements when the pushbutton **1MHz** is depressed.

Connect the probe to **CH.I** input. Depress the calibrator pushbutton **1MHz**. All other pushbuttons should be released (out position). Set the input coupling switch to **DC**, attenuator switch to  $5mV/div$ , and **TIME/DIV.** switch to  $0.1\mu s/div$ . Set all variable controls to **CAL.** position.

Insert the probe tip into the output socket marked  $0.2V$ . A waveform will be displayed on the CRT screen, with leading and trailing edges clearly visible. For the HF-adjustment now to be performed, it will be necessary to observe the rising edge as well as the upper left corner of the pulse top. The connecting boxes of the HZ51 and HZ54 contain one R-trimmer screw, each, while that of the HZ52 provides three. These R-trimmers have to be adjusted in such a manner that the beginning of the pulse top is as straight as possible. Overshoot or excessive rounding are unacceptable. This is relatively easy on the HZ51 and HZ54, but slightly more difficult on the HZ52. The rising edge should be as steep as possible, with the pulse top remaining as straight and horizontal as possible.

On the HZ52, each of the three trimmers has a clearly defined area of influence on the waveform shape (see Fig.), offering the added advantage of being able to straighten out waveform aberrations near the leading edge.

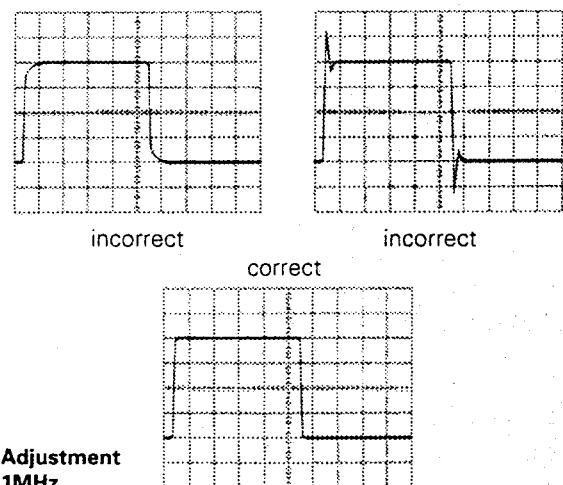

## Adjustment points of the probes

HZ51, HZ54

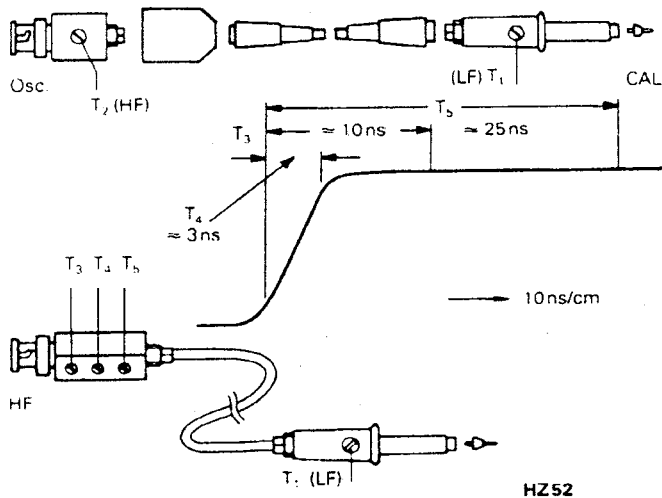

$T_3$ : alters the middle frequencies  
 $T_4$ : alters the leading edge  
 $T_5$ : alters the lower frequencies

After completion of the HF-adjustment, the signal amplitude displayed on the CRT screen should have the same value as during the 1kHz adjustment.

Probes other than those mentioned above, normally have a larger tip diameter and may not fit into the calibrator outputs. Whilst it is not difficult for an experienced operator to build a suitable adapter, it should be pointed out that most of these probes have a slower risetime with the effect that the total bandwidth of scope together with probe may fall far below that of the HM1007. Furthermore, the HF-adjustment feature is nearly always missing so that waveform distortion can not be entirely excluded.

The adjustment sequence must be followed in the order described, i.e. first at 1kHz, then at 1MHz. The calibrator frequencies should not be used for timebase calibrations. The pulse duty cycle may deviate significantly from 1:1 ratio.

Prerequisites for precise and easy probe adjustments, as well as checks of deflection coefficients, are straight horizontal pulse tops, calibrated pulse amplitude, and zero-potential at the pulse base. Frequency and duty cycle are relatively uncritical. For interpretation of transient response, a generator with fast pulse risetimes and low impedance outputs is of particular importance.

Providing these essential features, as well as switch-selectable output-frequencies, the calibrator of the HM1007 can, under certain conditions, replace expensive squarewave generators when testing or compensating wideband-attenuators or -amplifiers. In such a case, the input of an appropriate circuit will be connected to one of the **CAL.**-outputs via a suitable probe.

The voltage provided at a high-impedance input ( $1M\Omega$  ||  $15-50pF$ ) will correspond to the division ratio of the probe used ( $10:1 = 20mV_{pp}$ ,  $100:1 = \text{also } 20mV_{pp}$  from  $2V$  output). Suitable probes are HZ51, 52, 53, and 54.

## Operating modes of the vertical amplifiers

The vertical amplifier is set to the desired operating mode by using the 3 pushbuttons (CH I/II, DUAL and ADD) in the Y field of the front panel. For **Mono** mode all 3 buttons must be in their released positions; only **Channel I** can then be operated. The button **CH I/II-TRIG.I/II** must be depressed in mono mode for **Channel II**. The internal triggering is simultaneously switched over to Channel II with this button.

If the **DUAL** button is depressed, both channels are operational. Two signals can be displayed together in this button position (alternate mode) if the time-base setting and the repetition frequency of the signal are suited. This mode is not suitable for displaying very slow-running processes. The display then flickers too much or it appears to jump. If the **ADD** button is depressed in addition to **DUAL**, both channels are switched over constantly at a high frequency within a sweep period (**CHOP** mode). Low frequency signals below 1kHz, or with periods longer than 1ms are then also displayed without flicker. CHOP mode is not recommended for signals with higher repetition frequencies.

If only the **ADD** button is depressed, the signals of both channels are algebraically added ( $\pm I, \pm II$ ). Whether the resulting display shows the **sum** or **difference** is dependent on the phase relationship or the polarity of the signals **and** on the positions of the **INV.** buttons.

### In-phase input voltages:

Both **INV. CH I** and **INV. CH II** buttons released or depressed = sum.

Only **one INV.** button depressed = difference.

### Antiphase input voltages:

Both **INV.** buttons released or depressed = difference.

**INV. CH I** or **INV. CH II** button depressed = sum.

In the **ADD** mode the vertical display position is dependent upon the **Y-POS.** setting of **both** channels. The **same attenuator switch position** is normally used for both channels with algebraic addition. Please note that the **Y-POS.** settings are added too but are not affected by the **INV.** pushbuttons.

**Differential measurement** techniques allow direct measurement of the voltage drop across floating components (both ends above ground). Two identical probes should be used for both vertical inputs. In order to avoid ground loops, use a separate ground connection and do **not** use the probe ground leads or cable shields.

## X-Y Operation

### The following refers to analog mode:

For **X-Y mode** press the **X-Y MODE** button in the X field of the front panel. The X signal is then derived from the **Channel II (HOR. INP.)**. **The calibration of the X signal during X-Y operation is determined by the setting of the Channel II input attenuator and variable control.** This means that the sensitivity ranges and input impedances are identical for both the X and Y axes. However, the **Y-POS.II** control is disconnected in this mode. Its function is taken over by the **X-POS.** control. It is important to note that the **X-MAG. x10** facility, normally used for expanding the sweep is inoperative in the X-Y mode. It should also be noted that the bandwidth of the X amplifier is approximately 2.5MHz (-3dB), and therefore an increase in phase difference between both axes is noticeable from 50kHz upwards.

The Y-Input signal may be inverted by using the **INV.** facility. However, the inversion of the X-input signal using the **CH.II INVERT** button is not possible in analog mode.

**Lissajous figures** can be displayed in the **X-Y mode** for certain measuring tasks:

- Comparing two signals of different frequency or matching one frequency to the frequency of the other signal. This also applies for whole number multiples or fractions of the first signal frequency.
- Phase comparison between two signals of the same frequency.

### Phase comparison with Lissajous figure

The following diagrams show two sine signals of the same frequency and amplitude with different phase angles.

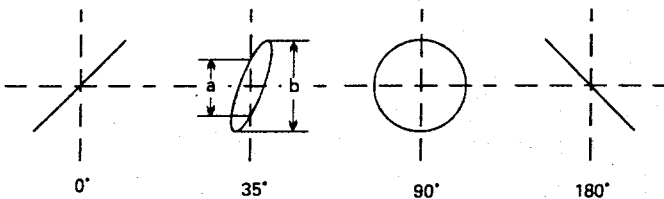

Calculation of the phase angle or the phase shift between the X and Y input voltages (after measuring the distances **a** and **b** on the screen) is quite simple with the following formula and a pocket calculator with trigonometric functions and is also **independent of both deflection amplitudes** on the screen.

$$\sin \varphi = \frac{a}{b}$$
$$\cos \varphi = \sqrt{1 - \left(\frac{a}{b}\right)^2}$$
$$\varphi = \arcsin \frac{a}{b}$$

### The following must be noted here:

- Because of the periodic nature of the trigonometric functions, the calculation should be limited to angles  $\leq 90^\circ$ . However here is the advantage of the method.
- Do not use a too high test frequency. The phase shift of the two oscilloscope amplifiers of the HM1007 in the X-Y mode can exceed an angle of  $3^\circ$  above 120 kHz.
- It cannot be directly determined from the screen display whether the test voltage leads or lags the reference voltage. A CR network before the test voltage input of the oscilloscope can help here. The  $1\text{ M}\Omega$  input resistance can equally serve as R here, so that only a suitable capacitor C needs to be connected in series. If the aperture width of the ellipse is increased (compared with C short-circuited), then the test voltage leads the reference voltage and vice versa. This applies only in the region up to  $90^\circ$  phase shift. Therefore C should be sufficiently large and produce only a relatively small just observable phase shift.

**Should both input voltages be missing or fail in the X-Y mode, a very bright light dot is displayed on the screen. This dot can burn into the phosphor at a too high brightness setting (INTENS. knob) which causes either a lasting loss of brightness, or in the extreme case, complete destruction of the phosphor at this point.**

### Phase difference measurement in DUAL mode

A larger phase difference between two input signals of the same frequency and shape can be measured very simply on the screen in Dual mode (**DUAL** button depressed). The timebase should be triggered by the reference signal (phase position 0). The other signal can then have a leading or lagging phase angle. Alternate mode should be selected for frequencies  $\geq 1\text{ kHz}$ ; the Chop mode is more suitable for frequencies  $< 1\text{ kHz}$  (less flickering). For greatest accuracy adjust not much more than one period and approximately the same height of both signals on the screen. The variable controls for amplitude and timebase and the **LEVEL** knob can also be used for this adjustment without influencing the result. Both base lines are set onto the horizontal graticule center line with the **Y-POS.** knobs before the measurement. With sinusoidal signals, observe the zero (crossover point) transitions; the sine peaks are less accurate. If a sine signal is noticeably distorted by even harmonics, or if an offset direct voltage is present, **AC** coupling is recommended for **both** channels. If it is a question of pulses of the same shape, read off at steep edges.

### Phase difference measurement in dual mode

$t$  = horizontal spacing of the zero transitions in div.

$T$  = horizontal spacing **for one period** in div.

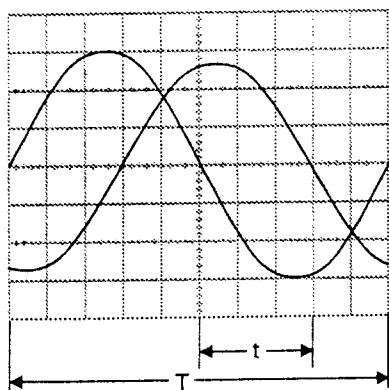

In the example illustrated,  $t = 3$  div. and  $T = 10$  div. The phase difference in degrees is calculated from

$$\varphi^\circ = \frac{t}{T} \cdot 360^\circ = \frac{3}{10} \cdot 360^\circ = 108^\circ$$

Relatively small phase angles at not too high frequencies can be measured more accurately in the X-Y mode with Lissajous figures.

### Measurement of an amplitude modulation

The momentary amplitude  $u$  at time  $t$  of a HF-carrier voltage, which is amplitude modulated without distortion by a sinusoidal AF voltage, is in accordance with the equation

$$u = U_T \cdot \sin \Omega t + 0,5m \cdot U_T \cdot \cos(\Omega - \omega)t - 0,5m \cdot U_T \cdot \cos(\Omega + \omega)t$$

where  $U_T$  = unmodulated carrier amplitude  
 $\Omega$  =  $2\pi F$  = angular carrier frequency  
 $\omega$  =  $2\pi f$  = modulation angular frequency  
 $m$  = modulation factor (i.a.  $\leq 1 \triangleq 100\%$ ).

The display of the amplitude-modulated HF oscillation can be evaluated with the oscilloscope in the analog mode provided the frequency spectrum is inside the oscilloscope bandwidth. The time-base is set so that several cycles of the modulation frequency are visible. Strictly speaking, triggering should be external at modulation frequency (from the AF generator or a demodulator). However, internal triggering is frequently possible with normal triggering (**AUTO/NORM** button depressed) using a suitable **LEVEL** setting and possibly also using the time variable adjustment.

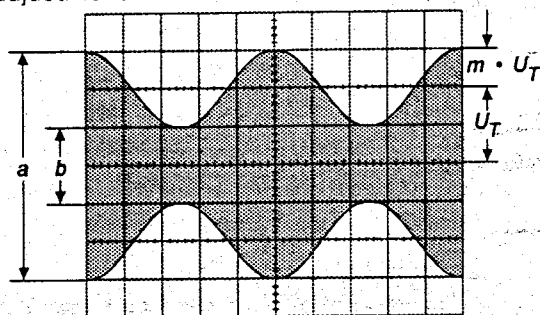

Figure 2

Amplitude modulated oscillation:  $F = 1$  MHz;  $f = 1$  kHz;  
 $m = 50\%$ ;  $U_T = 28.3$  mV<sub>rms</sub>.

Oscilloscope setting for a signal according to figure 2:

Depress no buttons. **Y: CH. I; 20mV/div.; AC.**

**TIME/DIV.: 0.2ms/div.**

Triggering: **NORM** with **LEVEL**-setting; **internal (or external) triggering**.

If the two values  $a$  and  $b$  are read from the screen, the modulation factor is calculated from

$$m = \frac{a-b}{a+b} \text{ resp. } m = \frac{a-b}{a+b} \cdot 100 [\%]$$

where  $a = U_T (1+m)$  and  $b = U_T (1-m)$ .

In certain cases (e.g. proportioning of a terminating resistor, diameter of wire of a modulation transformer, examination of an AM-tuning diode for cross modulation etc.), the following formula is of advantage:

$$\frac{U_{pp}}{U_{rms}} = 2 \cdot \sqrt{2} \cdot \frac{1+m}{\sqrt{1+\frac{m^2}{2}}}$$

$U_{pp}$  = peak-to-peak amplitude of an AM-voltage

$U_{rms}$  = effective voltage value of  $U_{pp}$  (on sine modulation only)

The variable controls for amplitude and time can be set arbitrarily in the modulation factor measurement. Their position does not influence the result.

### Triggering and timebase

**Attention:** With activated "trigger level display" (**TLD**) an applied input signal will be displayed untriggered. In **DUAL**-mode two untriggered signals would cause interpretation problems. Therefore only that signal is displayed which originates from the channel which is used as the internal trigger source (**CH I/II-TRIG.I/II** button).

A signal can be displayed only if the timebase is running or triggered. To produce a stationary display, triggering must be synchronous with the test signal. This is possible by using the test signal itself or by an externally supplied but synchronous signal voltage.

The trigger voltage should have a certain minimum amplitude. This value is called the trigger threshold. It is measured with a sine signal. When the trigger voltage is taken internally from the test signal, the trigger threshold can be stated as vertical display height in mm, from which the timebase generator starts, the display is stable, and the trigger LED lights.

The internal trigger threshold of the HM1007 is given as  $\leq 0.5$  div. When the trigger voltage is externally supplied, it can be measured in V<sub>pp</sub> at the TRIG. INP. socket. Normally, the trigger threshold may be exceeded up to a maximum factor of 20.

The HM1007 has two trigger modes, which are characterized as follows:

#### Automatic Peak-Triggering

With the **AUTO/NORM** pushbutton in out position (released = automatic triggering) the sweep generator is



running without test signal or external trigger voltage. A base line is always displayed even without a signal applied. With an applied signal the peak value triggering enables the user to select the voltage point on the trigger signal, by the adjustment of the **LEVEL** control. The LEVEL control range depends on the peak to peak value of the signal. This trigger mode is therefore called Automatic Peak (Value)- Triggering. Operation of the scope needs only a correct amplitude and timebase setting, for a constantly visible trace. AUTO mode is recommended for all uncomplicated measuring tasks. However, automatic triggering is also the appropriate operation mode for the "entry" into difficult measuring problems, e.g. when the test signal is unknown relating to amplitude, frequency or shape. Presetting of all parameters is now possible with automatic triggering; the change to normal triggering can follow thereafter.

The automatic triggering works above 10Hz up to at least 130MHz. The failure of automatic triggering at frequencies below 10Hz is abrupt. However, it is not signified by the trigger indicator (TR); this is still blinking. Break down of triggering is best recognizable at the left screen edge (the start of the trace in differing display height).

The automatic triggering functions on all variations or fluctuations of the test signal above **10Hz**. However, if the pulse duty factor of a square-wave signal exceeds a ratio of 100:1, switching over to normal triggering will be necessary.

Automatic triggering is practicable not only with internal but also with external trigger voltage.

### Normal Triggering

With normal triggering (**AUTO/NORM** pushbutton depressed) and **LEVEL** adjustment, the sweep can be started by signals within the frequency range selected by the TRIG. SEL. pushbutton.

***In the absence of an adequate trigger signal or when the trigger controls (particularly the LEVEL control) are misadjusted, no trace is visible.***

***In "refresh" storage mode, the most recently sampled waveform remains stored in memory.***

When using the internal normal triggering mode, it is possible to trigger at any amplitude point of a signal edge, even with very complex signal shapes, by adjusting the LEVEL control. Its adjusting range is directly dependent on the display height, which should be at least 0.5div. If it is smaller than 1div., the LEVEL adjustment needs to be operated with a sensitive touch. In the external normal triggering mode, the same applies to approx. 0.1V external trigger voltage amplitude.

Other measures for triggering of very complex signals are the use of the timebase variable control and HOLD OFF time control, mentioned below.

### Slope

The trigger point can be placed alternatively on a rising or falling edge of the test signal. This is valid with automatic and with normal triggering. The selected slope is set with the SLOPE +/- button. The plus sign (button released) refers to a positive going edge. That has nothing to do with zero or ground potential and absolute voltage values. The positive slope may also lie in a negative part of a signal. A falling edge (minus sign) triggers, when the +/- button is depressed.

However, with normal triggering, the trigger point may be varied within certain limits on the chosen edge using the LEVEL control.

### Trigger coupling

The coupling mode and accordingly the frequency range of the trigger signal can be changed using the **TRIG. SEL.** pushbutton. After switching the oscilloscope on, AC-coupling mode is selected automatically. By briefly pressing the TRIG. SEL. pushbutton, the next trigger coupling mode is called up. The sequence is: AC-DC-HF-LF---TV-AC etc.. If the TRIG. SEL. pushbutton is depressed for a longer time the trigger coupling is reset to AC. The coupling is indicated by a row of light emitting diodes, where the uppermost marked (**TR**) indicates triggering. In order to obtain a correct trigger level-marker display - correct in the sense that it is consistent with the input signal - both the input coupling and the trigger coupling must be switched to **DC** coupling.

#### AC:

Trigger range **≥ 10Hz to 40MHz**.

This is the most frequently used trigger mode. The trigger signal is coupled to the trigger comparator via a capacitor. Therefore the trigger sensitivity is decreasing below 10Hz. DC content of the trigger signal are suppressed.

#### DC:

Trigger range **DC to 40MHz**.

DC trigger coupling is recommended when displaying very low frequency signals and when it is required to trigger the signal at a specially selected voltage point (trigger level indicator), or when the signal constantly changes during investigation.

***Always work with normal triggering and LEVEL adjustment.***

#### HF:

Trigger range **30Hz to 130MHz** (high-pass filter).

The HF position is suitable for all radio-frequency signals. DC fluctuations are suppressed, giving a stable display. The trigger sensitivity decreases below 30Hz.

#### LF:

Trigger range **DC to 1kHz** (low-pass filter).

The LF position is often more suited for low-frequency signals than the DC position, because the (white) noise on the trigger voltage is strongly suppressed. So jitter or

double-triggering of complex signals is avoidable or at least reduced, in particular with very low input voltages. The trigger sensitivity decreases above 1kHz.

### Line triggering

A voltage originating from mains/line (50 to 60Hz) is used for triggering purposes if the ~-symbol lights up. This trigger mode is independent of amplitude and frequency of the Y signal and is recommended for all mains/line synchronous signals. This also applies within certain limits to whole number multiples or fractions of the line frequency. Line triggering can also be useful to display signals below the trigger threshold (less than 0.5div). It is therefore particularly suitable for measuring small ripple voltages of mains/line rectifiers or stray magnetic field in a circuit. In this trigger mode the **SLOPE** switch is inoperative. The **LEVEL** control can be used for slope selection if normal triggering (**AUTO/NORM** depressed) is used.

Magnetic leakage (e.g. from a power transformer) can be investigated for direction and amplitude using a search or pick-up coil. The coil should be wound on a small former with maximum turns of thin lacquered wire and connected to a BNC plug via a shielded cable. A resistor of at least 100Ω should be series-connected (RF decoupling) between the cable and the BNC center conductor. If possible the surface of the coil should be electrostatically screened, taking care not to cause shorted turns at the coil. Maximum, minimum, and direction to the magnetic source are detectable at the measuring point by turning and shifting the coil.

### Triggering of video signals

The built-in active **TV-Sync-Separator** separates the sync pulses from the video signal, permitting the display of distorted video signals in frame/line trigger mode.

Video signals are triggered in the automatic mode. The internal triggering is virtually independent of the display height, which may differ from 0.8 to 8 div. The **LEVEL** knob selects between frame (fully cw) and line (fully ccw).

The **TIME/DIV.** switch can be independently set according to the measurement task. For frame TV triggering, press the **TRIG. SEL.** pushbutton until **TV** is indicated and set the **LEVEL** control fully clockwise if automatic triggering (**AUTO**) is chosen. The integration required in this mode prevents all synchronization pulses from becoming visible. The slope of the leading edge of the synchronization pulse is decisive. So if the sync pulses at the test point are above the picture (field) contents, then the **SLOPE** pushbutton (+/-) must be in + position (out). In the case of sync pulses below the field, the leading edge is negative and the **SLOPE** pushbutton must therefore be depressed (to "-").

For line TV triggering the **LEVEL** control must be set fully counter-clockwise.

On the 2ms/div setting, with frame TV triggering and a 50 fields/s input signal 1 field is visible. It triggers without line interlacing affects, if the hold off control is in x1 position.

However, the **TIME/DIV.** knob may be turned more to the right (without loss of triggering) up to 0.5ms/div and an extended hold off time used to overcome line interlacing problems. Under these conditions more details in the video signal become visible while still one video field is suppressed. The 10-fold expansion with the **X-MAG. x10** button then enables one line to be displayed with a length of 1.2div in x-direction. Disconnecting the trigger circuit (e.g. by rapidly pressing and releasing the **EXT.** button) can result in triggering the consecutive (odd or even) field.

The sync-separator-circuit also operates with external triggering. It is important that the voltage range (0.1V<sub>pp</sub> to 2V<sub>pp</sub>) for external triggering should be noted. In addition, the correct slope setting is again critical, because the external trigger signal may not have the same polarity or pulse edge as the test signal. This can be checked, if the external trigger voltage itself is first displayed (with internal triggering).

In most cases, the composite video signal has a high DC content. With constant video information (e.g. test pattern or color bar generator), the DC content can be suppressed easily by AC input coupling of the oscilloscope amplifier. With a changing picture content (e.g. normal program), DC input coupling is recommended. This is because the display varies its vertical position on screen with AC input coupling at each change of the picture content. The DC content can be compensated using the **Y-POS.** control so that the signal display lies in the graticule area. Then the composite video signal should not exceed a vertical height of 6div.

### External triggering

The internal triggering is disconnected by depressing the **EXT.** button. The timebase can be triggered externally via the **TRIG. INP.** socket using a 0.1V<sub>pp</sub> to 2V<sub>pp</sub> voltage, which is in synchronism with the test signal. This trigger voltage may have a completely different form from the test signal voltage. Triggering is also possible within certain limits with whole number multiples or fractions of the test frequency, but only with synchronous signals.

The input impedance of **TRIG. INP.** socket is approx. 1MΩ || 25pF. The maximum input voltage of the input circuit is 100V (DC+peak AC).

### Trigger indicator

An LED on condition (above the **TRIG.** switch) indicates that the trigger comparator generates trigger pulses for the sweep generator. This is valid with automatic and with normal triggering. The indication of trigger action facilitates a sensitive **LEVEL** adjustment, particularly at very low signal frequencies. The indication pulses are of only 100ms duration.

For fast signals the LED appears to glow continuously, but for low repetition rate signals, the LED flashes at the

repetition rate of the trigger signal. This occurs not only at the start of the sweep, but also during the sweep cycle.

### Holdoff-time adjustment

If it is found that a trigger point cannot be located on extremely complex signals even after repeated and careful adjustment of the **LEVEL** control in the normal triggering mode, a stable display may be obtained using the **HOLDOFF** control (in the X-field). This facility varies the holdoff time between two sweep periods approx. up to the ratio 10:1. Pulses or other signal waveforms appearing during this off period cannot trigger the timebase. Particularly with burst signals or aperiodic pulse trains of the same amplitude, the start of the sweep can be delayed until the optimum or required moment.

**A very noisy signal or a signal with a higher interfering frequency is at times displayed double. Sometimes the LEVEL adjustment only controls the mutual phase shift, but not the double display. The stable single display of the signal, required for the evaluation, is easily obtainable by expanding the holdoff time. To this end the HOLDOFF knob is slowly turned to the right, until one signal is displayed.**

A double display is possible with certain pulse signals, where the pulses alternately show a small difference of the peak amplitudes. Only a very exact **LEVEL** adjustment makes a single display possible. The use of the **HOLDOFF** knob simplifies the selection of the correct display.

After specific use the **HOLDOFF** control should be reset into its calibration detent, otherwise the brightness of the display in analog mode is reduced drastically. The function is shown in the following figures.

Function of variable **HOLDOFF** control

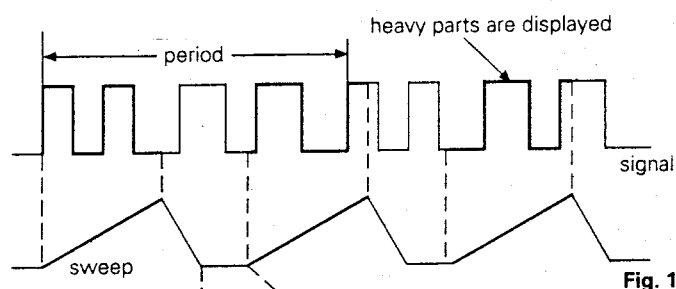

Fig. 1

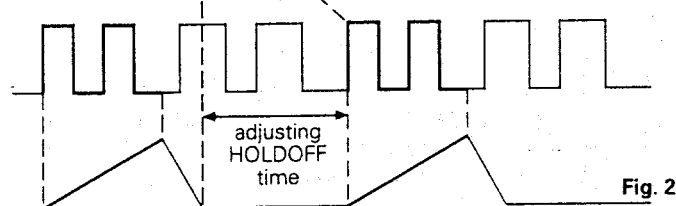

Fig. 2

Fig. 1 shows a case where the **HOLDOFF** knob is in the minimum position and various different waveforms are overlapped on the screen, making the signal observation unsuccessful.

Fig. 2 shows a case where only the desired parts of the signal are stably displayed.

### Trigger level display (TLD)

This facility makes the trigger point visible on the CRT screen by displaying a marker. Hence the level of the signal required for internal triggering becomes visible.

As long as the **TLD** (Trigger LEVEL Display) pushbutton is depressed, an applied input signal will be displayed untriggered or without an input signal, the baseline (0-Volt trace position) is visible. If the oscilloscope is operated in **DUAL** mode a two channel display could cause interpretation problems. Therefore under these conditions just that channel, selected as the internal trigger source, is displayed on the screen. Additionally a dashed line becomes visible, indicating the voltage level required for triggering. This marker can be moved vertically when using the **LEVEL** knob to adjust the trigger level. The trigger level display marker refers to the displayed signal, although the vertical position of the signal can be changed using the **Y-POS.** control. As a result, **Y-POS.** simultaneously affects both the signal and the trigger level marker.

When the **TLD** is in operation the **OVERSCAN** indicator should be ignored.

In order to ensure reliable trigger level display under all circumstances, the following scope settings are required: **DC** input coupling, **DC** trigger coupling, internal triggering, and normal triggering (**NORM.**). Otherwise the direct relationship between the measurement signal and the trigger signal will be lost.

Inversion of the measurement signal results in a signal display that no longer corresponds to either the trigger signal or the trigger level display.

The trigger level display function is especially useful for capturing nonrecurring events (**SINGLE**) in storage mode. When doing so, it is advisable to use the **Y-POS.** control to fix a suitable 0-volt position. For example, in order to capture a signal in the positive voltage range this position would be the lowest horizontal graticule line. If it is wished to determine whether a voltage exceeds +5V, set the trigger level so that the TLD marker is situated 5.5 div. above the 0-volt line. When measuring with a 10:1 attenuator probe the attenuator switch should be set to the 0.1V/DIV. position. The resulting deflection coefficient is then 1V/DIV., and the trigger level is consequently 5.5 volts.

After these preparations have been made, wait for the input voltage to rise with the scope set to storage mode, **DC** input coupling, **DC** trigger coupling and normal triggering, and the **SINGLE** and **RESET** buttons depressed. The slope direction button (**SLOPE**) should remain in its released position (+).

---

## Y Overscanning Indication

This indicator shows any vertical overscan of the usable (10 x 8) screen area, if any part of the signal or baseline are outside the graticule. The indication is achieved by 2 light-emitting diodes, marked **OVERSCAN**, which are located in the center between the attenuators. Should one LED illuminate without an input signal, this means that the respective vertical positioning control has been improperly adjusted. The upper LED relates to the upper direction and vice versa. So it can be seen in which direction the trace has left the screen. With dual channel operation, misadjustment of both **Y-POS** controls can occur. If both traces lie in the same direction, the relevant LED illuminates. If one trace is positioned above and the other below the graticule, both LEDs are illuminated. The overscan indication occurs in **each operating mode**, including, due to missing time deflection (untriggered), when no baseline is displayed, or when the oscilloscope is in the X-Y mode.

As previously written in the paragraph "First Time Operation", the **AUTO/NORM** pushbutton should be switched in AUTO position, as a baseline is then permanently displayed, even without any input signal. The trace may sometimes disappear after applying an input signal. The LED indication shows in which direction the trace has left the screen, above or below the graticule. Illumination of both LEDs at the same time after applying a signal means that the vertical deflection has overscanned the graticule edges in both directions. With DC input coupling and an applied signal with a relatively high DC offset, small signals can overscan the raster edges, because the DC voltage causes a vertical position shift of the display height. In this case, a smaller display height must be accepted, or **AC** input coupling has to be selected. Changing the Y-POS setting may also be a solution.

## Scale Illumination

Especially for the photographic recording of displays, the oscilloscope has **graticule illumination**. Normally, the graticule, which is necessary for the point-by-point evaluation, is not visible without illumination. Possibly some test pictures are required for a good representation of the graticule.

---

## Storage mode

The HM1007 has an 8-bit flash A/D converter for each channel. The maximum sampling rate that can be driven by the digital timebase is **40 MS/s** (40 million samples per second). Where signal capture is concerned, there is essentially no difference between capture of repeating signals and recording of one-time signal events. For the

improvement of waveform recognition, the successive dots are linearly joined by luminescent lines.

Signal capture can either be performed in response to a trigger in either **SINGLE** or **REFRESH** mode, or else trigger-independent (untriggered) in **ROLL** or **X-Y** mode. ROLL mode can only be used in the "s" (for seconds) time-base range from 0.1s/div. to 50s/div. (marked on the front panel with a dotted line). The time-base is switched over to these ranges automatically, if the ROLL-button is depressed.

In **ROLL** mode, the contents of memory and thus also the signal display are continuously updated. Because signal capture is untriggered, no idle states arise while waiting for a new trigger event to start signal capture again. With each new sampling cycle, therefore, the previously captured data are shifted to the left by one address. The leftmost value (shown at the left-hand edge of the screen) is thus shifted completely out of memory and lost.

The display obtained in **REFRESH** mode is equivalent to that of an analog oscilloscope. With each trigger event, a "writing sweep" is performed, beginning at the left-hand screen edge and ending at the right-hand edge. The next trigger event then starts signal capture again, overwriting the data of the previous sampling cycle.

In order to also permit capture of an event's prehistory, the HM1007 is equipped with a **pretrigger function** that can be switched to either **0% (PRE TRIG. button released)** or **50% (PRE TRIG. button depressed)**. This function lets you capture signals occurring prior to a trigger event. It follows from this that pretriggering can only be used in those operating modes in which signal data are captured in response to a trigger event (**SINGLE** and **REFRESH** modes). The only exception to this is in REFRESH mode, if the timebase is driving a low sampling rate (**ms/s** pushbutton depressed). In this case there is no pretriggering (i.e. 0% pretriggering) in order to avoid excessively long waits until the signal display is updated again. If you wish to perform measurements with pretriggering in these time-base ranges, then you must switch to SINGLE mode.

The signal data captured in digital storage mode can be accessed for documentation purposes via the HAMEG interface. It is also possible to transfer external data into the memory, thus causing it to be displayed on-screen.

## Controls and indicators of the storage section and their functions

In general, the storage mode controls and indicators are grouped together in the X field, and are framed to set them apart. The exceptions are the **Y REFERENCE POSITION**, the

---

**X MAGnifier** **STOR**age (**x5**) and the **ms/s** time button. The storage controls are inoperative in analog mode.

**STORE.:** When this pushbutton is locked into its depressed position, the scope is switched from analog (realtime) to storage operation, and the "**STOR.**" **LED** lights up to indicate this. Pressing the button again releases it, returning the scope to analog mode and extinguishing the LED. Any signals previously stored with **HOLD** remain stored in memory.

The "**STOR.**" LED remains constantly lit to indicate that storage mode is active. If this LED begins flashing on and off, then the **TIME/DIV.** switch is incorrectly set. This can be the case if it is set to positions outside of the black-bordered **TIME/DIV.** scale, or if it is set to a position outside of the area marked by a dotted line while the **ms/s** or the **ROLL** button is depressed.

If the time/division switch is set to the **CLK.EXT** position (external clock), then the "**STOR.**" LED will not flash on and off.

**HOLD:** Pressing the **HOLD** pushbutton saves the memory contents currently displayed on-screen, protecting them against being overwritten by new data. This can affect either just one of the channels (in **MONO** mode) or both channels (in **DUAL** and **X-Y** modes). **HOLD** can be pressed at any time, immediately halting any further updating of the memory contents.

Particularly when using slow time-base positions for triggered operation, it is actually possible to observe how the old memory contents are successively overwritten by new data. If the **HOLD** button is then pressed in the middle of a sampling cycle, a breakpoint or irregular joint may result between the new data and the old data. This effect can be avoided by performing a signal capture in single-shot mode, even if a repeating signal is being studied. This results in a complete new sampling cycle that is then no longer overwritten once completed. Afterwards the **HOLD** button can be pressed to prevent the data from being overwritten again by accidentally pressing **RESET**.

**REF.:** When the **REF.** (= reference) pushbutton is pressed, the momentarily displayed data are copied into the reference memory block. It makes no difference whether the data are being displayed in **Y(t)** or **X-Y** mode, or whether **MONO** or **DUAL** operation has been selected. The contents of the reference memory block can only be changed by pressing **REF.** again. It doesn't matter if the signal or signals to be transferred have previously been stored by pressing **HOLD**.

**DISP. REF.:** If the **DISP. REF.** (= display reference) pushbutton is locked into its depressed position, the

contents of the reference memory block are displayed in addition to the current signal image. In **DUAL** mode, it is possible to display and view two reference signals that have been previously stored in **DUAL** mode, or two reference signals that have been successively stored in **MONO** mode from channels I and II.

**REF.-POS.:** The displayed reference signal can, using the **REF.-POS.** (= reference position) knob in the **Y** field, be shifted upward by up to about 4 divisions in order to separate it from the current signal display and make it easier to compare them with one another. If the **REF.-POS.** knob is turned all the way to the left, then the reference signal is displayed at its original position. The change in position is performed in the analog section of the **HM1007**; the data stored in the reference memory block are not affected in any way.

The reference signal cannot be moved in **X-Y** mode.

**SINGLE SHOT** pushbutton: This is used to switch over to one-time event recording. If a scan is in progress when **SINGLE** mode is activated, then the scan is first completed instead of being interrupted. If the **ms/s** switch is in its **s** (for seconds) position, then the completion of the scan is depicted as a roll operation (the signal is moved towards the left-hand screen edge).

In this way, nonrecurring waveforms (e.g. power-up or power-down events, or randomly occurring signals) can be displayed with uniform screen brightness and stored for as long as desired.

**Pretriggering (if activated) is always enabled in SINGLE mode.**

**RESET** pushbutton: If, after a sweep has been completed, the **RESET** button is pressed while the **SINGLE** button is in its depressed position, the **RESET** LED lights up. This indicates that the oscilloscope is ready to perform a single scan, and the scope immediately begins capturing signal data. After a trigger event and completion of the sampling cycle, data capture is halted. Especially when capturing signals in the seconds time-base range, it is important to keep in mind that the time for capture of a signal's prehistory must elapse first before a trigger event can take effect. If this were not so, then the recorded prior history of the displayed signal would not correspond to the pretrigger value.

After completing a sampling cycle, the **RESET** pushbutton can be pressed to turn the **RESET** LED (which has meanwhile gone out) back on and initiate a new sampling cycle, thus overwriting the previously captured signal data.

While the **ms/s** time-base range switch is in its "**s**" position, the signal data captured in **SINGLE** mode are

immediately visible. They are shown in the form of a roll display, but this is the only feature associated with ROLL mode.

**PRE-TRIG.** pushbutton: The PRETRIGGER function is used to capture signals that occur prior to a trigger event. When the PRE-TRIG. button is in its depressed position, the trigger event's prehistory extending back over 50% of the screen width is captured; in its released position, the pretrigger function is switched off (0%). As was already mentioned, the pretrigger function can only be activated in triggered operating modes, i.e. not in the X-Y and ROLL modes. Pretriggering is always enabled in **SINGLE** mode, and **disabled** (i.e. set to 0%) when measuring in the **seconds** time range in REFRESH mode (NORM. triggering) in order to avoid excessive wait times while capturing periodically occurring signals.

The pretrigger value refers to the x-axis of the screen display. For instance, with the time/division switch set to **1 ms/div.** the displayed prehistory (i.e. signals prior to the signal event) extends back over a time period of **5 ms (50%** of 10 divisions x 1 ms). The trigger event is thus displayed **5 div. from the left-hand graticule edge.**

**X-MAG. STOR.x5:** If this pushbutton is depressed, the signal is extended 5-fold in x-direction. This function is only available in storage mode. In combination with **X-MAG. x10** the extension becomes **50-fold**. Both facilities are inoperative in X-Y mode.

**ROLL** pushbutton: This pushbutton is used to switch over to ROLL mode. As already mentioned this mode is only available in the timebase range from **50s/div** up to **0.1s/div**. Therefore the ms/s switch is set automatically to **s** (seconds) mode.

With each trigger independent signal sampling the new data value is shown in the right-hand position of the screen, while the previously captured data are shifted to the left. The leftmost value is shifted out of memory and lost.

**TIME/DIV.** rotary switch: When storage mode is active, the digitally generated, crystal-controlled timebase generates the pulses for signal data capture. The sampling rate is set using the TIME/DIV. switch; the fine-adjustment knob is disabled, however. Because the sampling rate is limited to a maximum frequency of **40MS/s** (40 million samples per second), and because 2k bytes of memory are available for storage of the data (2000 sampling values, displayed over 10 divisions in the x direction), the lowest selectable time coefficient in storage mode is **5µs/division**. This can be increased to a maximum of **50ms/division** using the TIME/DIV. switch. This range is surrounded by a black border line around the time/division scale, and is active whenever the **ms/s** switch is set to "**ms**" (in its released position).

Since even larger time/division coefficients are useful when using the scope in storage mode, they can be expanded by a **factor of 1000**. To do so, set the ms/s switch to "**s**" (seconds). The area of the scale surrounded by the dashed border line is now active. Time coefficients between **50 s/division** and **0.1 s/division** can be set. The time-base is switched over to these ranges automatically, if the ROLL-button is depressed.

**CLK.EXT.:** If the TIME/DIV switch is set to CLK.EXT. (fully ccw), then the internal timebase is deactivated. An external clock signal can now be applied by way of the BNC connector on the scope's rear panel. When doing so, the following conditions must be met:

<b>Max. frequency:</b>	5 MHz
<b>Input voltage:</b>	0 to +5 V
<b>Low signal:</b>	0 to +0.3 V
<b>High signal:</b>	+3 to +5 V
<b>Sampling pulse duration:</b>	> 45 ns for high signals
<b>Signal edge for sampling:</b>	positive-going signal edge

External clock signals can be used for all storage measurement modes. If the frequency of the external time-base signal is less than 2 kHz, then it is advisable to select **ROLL** mode. The **ms/s** switch is inoperative.

**X-Y** pushbutton: If STOR. is depressed and the X-Y pushbutton (outside of the storage control field) is locked in its depressed position, then the HM1007 is in X-Y storage mode. This differs from X-Y analog mode in the following respects:

The timebase is enabled, since no signal sampling can be performed without it (unless an external clock signal is applied).

The vertical position control for Channel II (**Y-POS. II**) functions as a horizontal position control. The **X-POS.** control is disabled.

The input signal of **Channel II** can be **inverted** with **INV. CH II.**

If measurements are performed with excessively small deflection coefficients, then the sampling rate is so high that complete sampling operations are no longer possible on an X or Y signal period. This results in gaps in the display.

If the selected time/division setting is too large, on the other hand, several periods will be sampled. If the X and Y signals are not phase-coupled with one another, the result will be a display with poor definition. It does, however, correctly show the varying phase relationships that occur during sampling and capture.

It is easier to find the right time-base position if both signals are first displayed in refresh mode with DUAL enabled. Then set the TIME/DIV. switch so that each



channel displays at least one signal period. Afterwards the scope can be switched to X-Y mode.

As already mentioned, the Y-POS.II control functions as a horizontal position control in X-Y storage mode. The marking on top of the Y-POS-II (Y-position, Channel II) control knob should be pointing straight up, unless a DC voltage component must be compensated for. The maximum deflection range of the A/D converter is approx. 10 cm; however, it is only in X-Y mode that the resulting limitations at the left and right edges of the graticule are recognizable, causing distortion as these are approached.

In order to save a displayed waveform in X-Y storage mode, simply press the HOLD button.

It is important to note that both the X-MAG. x10 and X-MAG. STOR. x5 facilities and the REF.-POS. control are inoperative in X-Y mode.

## Storage resolution and operating modes

### Vertical resolution

The dot density in each operating mode is 8 bits =  $2^8 = 256$  dots displayed over a height of roughly 10 cm (25 dots per division). However, only 8 divisions within the screen graticule can be evaluated.

### Horizontal resolution in time-base mode Y(t)

The dot density per channel is 11 bits =  $2^{11} = 2048$  dots. Of these, 2000 dots are displayed over a width of 10 cm (200 dots per division). The remaining 48 dots fall beyond the right-hand edge of the screen graticule.

### Dot density in X-Y mode: 250x250 dots over 10 divisions.

### Horizontal resolution with X magnification

In digital storage mode it is possible to expand the signal display in the x direction. This is equivalent to increasing the sampling rate while simultaneously reducing the horizontal resolution. This magnification is performed in the analog X portion of the HM1007, and has no effect on the stored data.

Whereas only 10x horizontal magnification is possible when using the scope in analog mode, in digital storage mode both **10x** and **5x** are available, as well as the use of both expansion factors together to yield **50-fold** magnification. For Yt operation, x magnification results in the following dot densities:

X x 5 = 40 dots/division

X x10 = 20 dots/division

X x50 = 4 dots/division

X magnification results in expanded display of just one section of the stored signal; the desired section can be selected using the X-POS. control (coarse and fine).

## Maximum signal frequency in storage mode

The highest capturable signal frequency cannot be exactly defined, since it depends to a large extent on the waveform and the displayed amplitude (vertical deflection) of the signal.

With the start of each sweep, the signal voltage at the inputs of the analog-to-digital converters is briefly measured (sampled), converted to an 8-bit digital value, and written to an address in RAM. The next sampled value is converted in the same way, but stored at the next RAM address.

The time intervals between the individual signal samples are determined by the time-base setting. At the maximum sampling rate of 40 megasamples/s (40 MHz) - on the time-base setting 5  $\mu$ s/div. - every 25 ns the A/D converters are briefly switched to "measurement". Assuming that 10 measurements per signal period are sufficient, this yields a minimum signal period duration of  $10 \times 25 \text{ ns} = 250 \text{ ns}$ , corresponding to a maximum signal frequency of 4 MHz. Since the memory capacity is 2k bytes = 2048 measurements, which are displayed over a trace width of approx. 10.2 divisions, 10 sampling values (corresponding to a period of 4 MHz) are displayed within a horizontal deflection of 0.5 mm. For evaluation purposes, it is therefore advisable to display this signal frequency with X-MAG.x10. This results in a signal period being displayed over 5 mm, or over 25 mm if X-MAG.x5 is also used, making the signal easier to evaluate.

The displayed trace height in the y direction also has an effect on the quality of signal representation. For instance, a sine wave depicted with 10 samples per period can be less clearly recognized at a signal height of 8 divisions than with an amplitude of 2 divisions.

If the sampling rate is too low, aliasing can result (see figure).

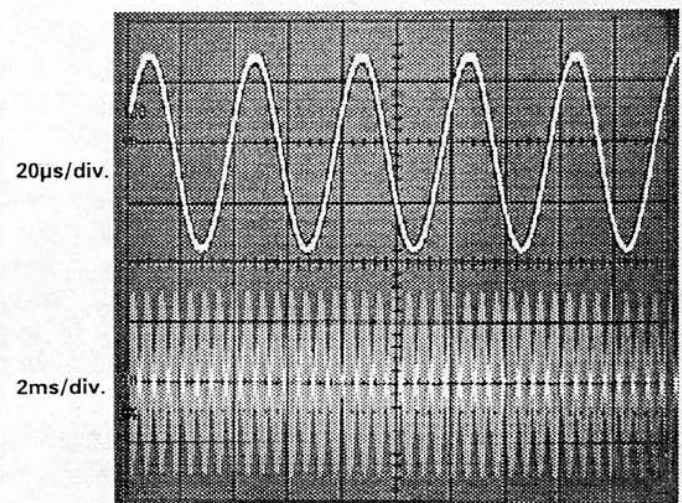

## Operating modes of the vertical amplifiers

In principle, the HM 1007 can operate in digital storage mode with the same operating modes as in analog (realtime) mode. Thus, the following can be displayed:

- Channel I by itself
- Channel II by itself
- Channels I and II simultaneously
- The sum of both channels
- The difference between Channel I and Channel II
- X-Y mode

Storage mode differs from analog operation of the scope in the following respects:

- With the DUAL button depressed (for simultaneous display of the signals of both channels), both input signals are also simultaneously captured, since each channel has its own A/D converter. In contrast to analog mode, therefore, it is not necessary to switch between chopped and alternating mode. Pressing the CHOP. button has no effect.
- Because of the high refresh rate (approx. 60 Hz) of the screen display, no flicker can occur.
- The storage timebase is also active in X-Y storage mode.

## Protection of the memory content

The memory contents of the HM1007 would normally be lost after switching off the power. However this can be avoided by fitting 2 ALKALINE 1.5 Volt microcells (MN2400 = LR03 = SIZE AAA) into the battery holder in the rear of the oscilloscope.

First remove the power supply connector from the oscilloscope. Then place the oscilloscope face down on a soft surface, and remove the back cover. The battery holder will then be visible. Observe the polarity symbols and fit the two batteries accordingly. Then refit the back panel into place.

When it is required to save stored signals in the oscilloscope, before switching off the power, depress the HOLD pushbutton to avoid unwanted overwriting of the memory contents when the oscilloscope is switched on again.

It is recommended to remove the microcells if the oscilloscope will not be operated for some time.

## HAMEG interface

The rear panel of the HM 1007 contains a 26-pin connector that can be used to access the data stored in memory for documentation purposes. With the exception of the reference position (REF. POS.), only signal data are available. The data can be read out either directly in digital form, or converted to analog signals first. It is also possible (by employing suitable external equipment) to transfer data (digital only) into the oscilloscope's memory, thus causing it to be displayed on-screen. This is a useful

feature because - in contrast to data display on a computer's monitor with its limited horizontal resolution - it permits display of signals with the full resolution of the 2k-byte memory.

Data can be transferred directly, i.e. without an interface, to a HAMEG Graphics Printer for hardcopy of the currently displayed data. This can be done in various different operating modes. The X magnification factors possible with the scope are ignored by the external device. For more detailed information, please consult the operating manual of the graphics printer.

Use of the externally connectable HAMEG interface HO79-4/-7 permits use of the following ports for documentation purposes:

- Analog, for X-Y recorders
- Parallel, for devices with CENTRONICS connector
- RS232, for bidirectional communication
- IEEE-488, for bidirectional communication and "talk-only" operation

Different data formats can be used.

In addition, data can be transferred to the HM1007's memory by way of the HO79-4/-7.

Pin 1 is indicated by a triangle on its plastic housing. The pins adjacent to it have odd numbers in the sequence 3, 5, 7 ... 25.

The pin pointing away from the symbol is pin 2; this row has even numbers between 2 and 26.

Pin assignments and their meanings:

Pin	Name	Active	Type	Function
1	GND	-	-	Reference potential (digital)
2	-	-	-	-
3	HB0	-	Data	Bit 0 (LSB) bidirectional
4	HB1	-	Data	Bit 1
5	HB2	-	Data	Bit 2
6	HB3	-	Data	Bit 3
7	HB4	-	Data	Bit 4
8	HB5	-	Data	Bit 5
9	HB6	-	Data	Bit 6
10	HB7	-	Data	Bit 7 (MSB)
11	+5VHB	-	-	Supply voltage of scope approx. +4.5V/150mA
12	GND	-	-	Reference potential (analog)
13	XPLOT	-	-	X analog voltage for X-Y recorder
14	-	-	-	-
15	YPLOT	-	-	Y analog voltage for X-Y recorder
16	X-Y	LOW	OUT	X-Y mode: low level
17	DATAVAL	LOW	INP/OUT	Data valid: low level
18	CLRAC	LOW	INP	Reset address counter: low level

19	CLKAC\	HIGH	INP	Clock input of address counter Leading edge increments counter address by 1
20	SRQ	HIGH	INP	Service request: high level interrupts internal readout clock
21	HBWR\	LOW	INP	Read/write switchover: low level lets data be written into scope memory
22	TE\	LOW	OUT	Transmit enable: low level signalizes ready-to-transmit
23	HBRESET\	LOW	INP	Set single mode: low level sets RESET mode (LED lights up)
24	-	-	-	-
25	GND	-	-	Reference potential (digital)
26	GND	-	-	Reference potential (digital)

Explanations: INP = Input signal for HM1007  
 OUT = Output signal from HM1007  
 LOW = HCMOS low level, 0 to 1.35V  
 HIGH = HCMOS high level, 3.15 to 5V

**Attention:**

The following conditions must be met when connecting external equipment to the HAMEG interface:

The input voltages may only be in the range from 0 to +5 V. The outputs are not short-circuit-proof; the load must therefore have a minimum impedance of 2kΩ.

**Readout of data memory:**

The following information is provided merely to aid you in understanding the processes involved. With the HAMEG Graphics Printer or the HO79-4/7 they are largely automated.

Before reading out the contents of the data memory, the states of the data lines indicate the oscilloscope type. If HB1 is high while all other data lines are in their low states, the oscilloscope is recognized as the HM1007.

During readout, the data lines carry levels corresponding to the memory contents.

The memory contents are read out as follows:

1. SRQ goes high = service request.
2. TE\ is continually polled until it is in its low state, thus indicating the HM1007 is ready to transmit.
3. X-Y is polled. If it is low (= X-Y mode), then step 4 is skipped. Since no shifting of the baseline position is possible in X-Y mode, it is not necessary to query this information.

4. The data lines now carry the amount of the baseline position shift (REF.-POS.) as an 8-bit value. If it has been shifted by one division, the data lines (MSB to LSB) carry the states 00011001, corresponding to decimal 25, which is the vertical resolution.

5. CLRAC\ is briefly pulled low so that the readout operation can be initiated.

6. The CLKAC\ (clock address counter) line is toggled from low to high (positive-going signal edge). After this the data lines carry the data of byte 0 until the next leading edge makes byte 1 available. Each positive-going signal edge must of course be followed by a negative-going edge (resulting in a square-wave signal).

The memory contents must always be completely read out (4 x 2048 bytes), regardless of what operating mode the scope is in (mono/dual, with/without active reference memory block). While the currently valid, i.e. displayed, 2-kilobyte data blocks are being read out, this is indicated by a low state on DATAVAL\ . Any devices connected to the HAMEG interface only document the currently valid data blocks.

The signal data are always output in the following sequence: 2048 bytes of Channel I data, 2048 bytes of Channel II data, 2048 bytes of reference data for Channel I, and 2048 bytes of reference data for Channel II.

7. SRQ is pulled back low, thus ending readout and putting the HM1007 back into normal operating mode.

**Automatic readout of single-shot events**

The following is a description of how data are read out in SINGLE mode. The SINGLE button must be depressed, and the scope must have been prepared for a trigger event by pressing the RESET button.

Since what happens in this case is largely identical with the sequence just described in detail in the previous section, only the differences are discussed here.

A: First the TE\ line is queried as described in step 2. A low state on TE\ signals that the HM1007 has captured a signal event and has completed data capture. Then the signal data are transferred following the same sequence of steps 1 through 7. While this is happening, TE\ again performs its normal function as described in step 2.

B: HBRESET\ is briefly pulled low. This puts the HM1007 back into readiness for a new trigger event, and the RESET LED lights up. Upon receipt of a trigger event, the process continues as described in step A.

---

## Writing data into memory

As already mentioned, it is also possible to write data into the oscilloscope memory by way of the HAMEG interface. These data must have first been stored on a data storage device, e.g. a hard disk. The data can be transferred by the computer using either a serial (RS-232C) or parallel (IEEE-488 bus) port, passing through the HO79-4/-7 and being deposited in the HM1007's memory.

This permits digitally stored signals to again be displayed on the scope with full horizontal resolution, which cannot usually be done on the computer's monitor owing to the poorer resolution of the graphics cards used. Another valuable use of this feature is for loading reference signals into the scope, which can then be immediately compared with currently measured input signals. The alternative, namely to send current signals to the computer and perform comparisons on the PC monitor, is slower because of the data transmission times involved.

If data are written into the reference memory blocks only, no further steps are required. If, however, it is also wished to write data into other memory blocks then it is a good idea to first depress the HOLD button. Otherwise new information from the A/D converter may immediately overwrite the data.

The procedure followed is largely identical with that used for data readout:

1. SRQ goes high = service request.
2. HBWR\ is activated by a low level. This switches the scope to write mode.
3. TE\ is continually polled until it is in its low state, thus indicating that the HM1007 is ready.
4. CLRAC\ is briefly pulled low so that the write operation can be initiated.
5. The data for byte 0 are placed on the data lines.
6. The CLKAC\ (clock address counter) line is toggled from low to high (positive-going signal edge). The data previously

placed on the data lines are then written into memory, and at the same time the counter address is incremented to byte 1. Afterwards the data for byte 1 are placed on the lines and another positive-going signal pulse is sent to CLKAC\ . Each positive-going signal edge must of course be followed by a negative-going edge (resulting in a square-wave signal).

With CLKAC\ , the entire memory address space must be run through, regardless of what operating mode the scope is in (mono/dual, with/without active reference memory block). The 2k-byte memory block or blocks into which data are to be read are indicated to the oscilloscope by a continuous low state on DATAVAL\ .

The signal data are also always written in the following sequence:

2048 bytes of Channel I data, 2048 bytes of Channel II data, 2048 bytes of reference data for Channel I, and 2048 bytes of reference data for Channel II.

7. SRQ is pulled back low, thus ending the write operation and putting the HM1007 back into normal operating mode.

---

## Safety note

***All connections of the interface have a galvanic connection to the protective earth line, as the oscilloscope has to be operated under Safety Class I conditions.***

***Measurements of high measurement reference potentials are therefore not possible, and run the risk of damaging the oscilloscope, the interface, and any connected devices.***

***If the safety instructions are not followed (see also "Safety" on page M 1), then any resulting damages to HAMEG products are excluded from the warranty. Nor does HAMEG assume any liability for injury to persons or damage to other makes of equipment.***

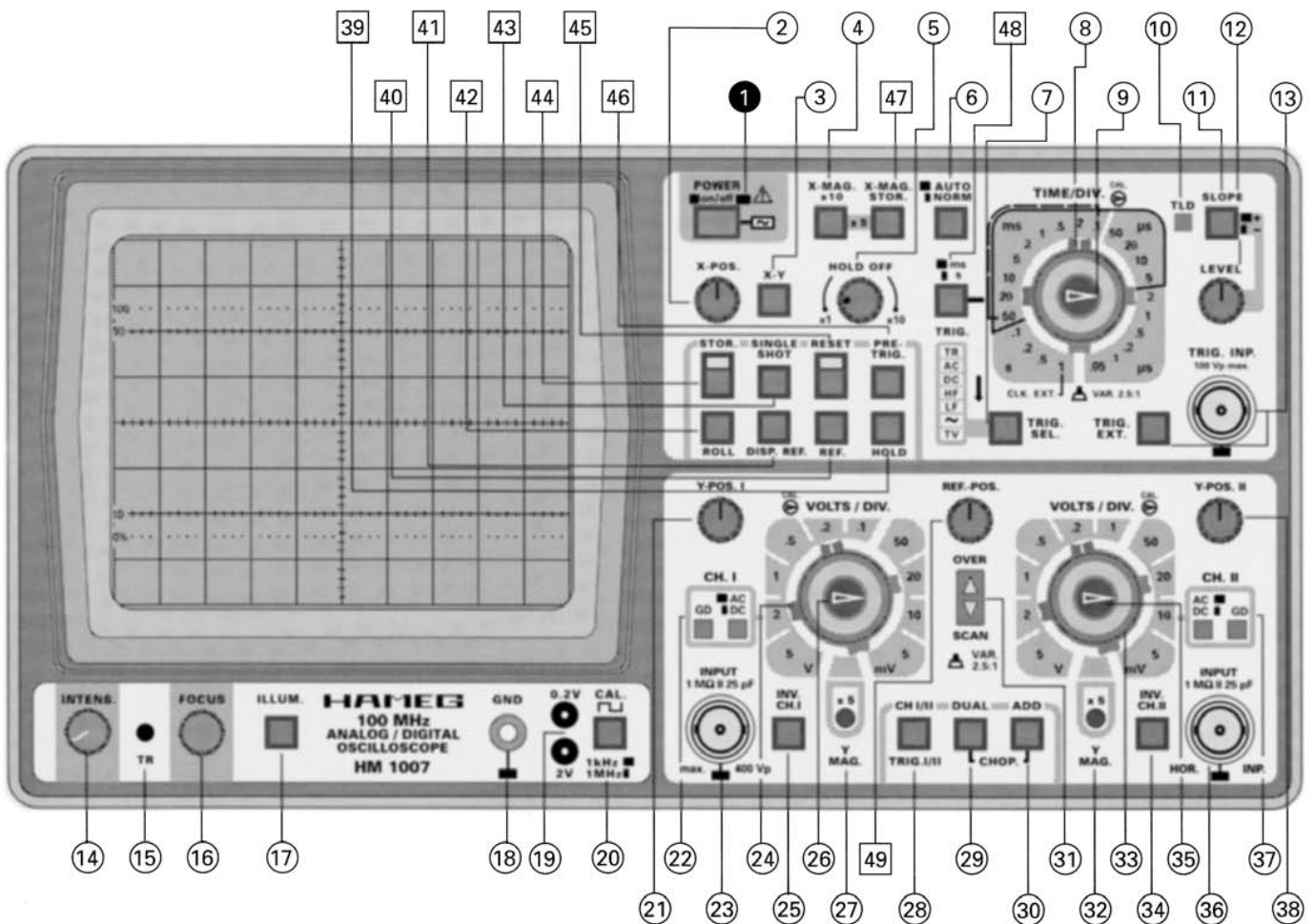

### Bedienungselemente für den Speicherbetrieb:

Element	Funktion	Element	Funktion
39 <b>HOLD</b> (Drucktaste)	Sicherung des auf dem Bildschirm sichtbaren Speicherinhalts	45 <b>RESET</b> (Tipptaste; LED)	Bereitet auf Einzelereignis-Erfassung vor. LED zeigt Aufnahmebereitschaft an. LED erlischt nach Signalerfassung.
40 <b>REF.</b> (Drucktaste)	Übernahme der momentan sichtbaren Daten in den Referenzspeicher.	46 <b>PRETRIG.</b> (Drucktaste)	Erfassung der Signal-Vorgeschichte mit 50% Pretrigger bezogen auf die Bildschirmdarstellung.
41 <b>DISP. REF</b> (Drucktaste)	Darstellung des Referenzspeicher-Inhalts	47 <b>X-MAG. STOR. x5</b> (Drucktaste)	Zusätzliche X-Dehnung im Speicherbetrieb um den Faktor 5
42 <b>ROLL</b> (Drucktaste)	Zur Umschaltung auf ROLL-Betrieb (50s/Div. bis 100ms/Div.).	48 <b>ms/s</b> (Drucktaste)	Bei gedrückter Taste werden die gestrichelt umrandeten Werte der TIME/DIV.-Skala um den Faktor 1000 erweitert. (Sekunden-Zeitbereich)
43 <b>SINGLE SHOT</b> (Drucktaste)	Einzelablenkung. Verhindert weitere periodische Zeitablenkvorgänge.	49 <b>REF.-POS.</b> (Drehknopf)	Verschiebung des Referenzsignals auf dem Bildschirm in Y-Richtung.
44 <b>STOR.</b> (Drucktaste und LED)	Schaltet das Oszilloskop von Analog- auf Speicherbetrieb um. LED zeigt den Betriebszustand an (Dauerlicht). Blinkt, wenn Zeitbereich falsch gewählt.		

# Bedienungselemente HM 1007 (Kurzbeschreibung – Frontbild)

Element	Funktion	Element	Funktion
① <b>POWER on/off</b> (Taste + LED-Anzeige)	Netz Ein/Aus; Leuchtdiode zeigt Betriebszustand an.	②① <b>Y-POS. I</b> (Drehknopf)	Einstellung der vertikalen Position des Strahles für Kanal I.
② <b>X-POS.</b> (Drehknopf)	Strahlverschiebung in horizontaler Richtung (nicht im XY-Speicherbetrieb).	②② <b>GD-AC-DC</b> (Drucktasten)	Tasten für die Eingangssignalankopplung von Kanal I. AC/DC-Taste gedrückt: direkte Ankopplung; AC/DC-Taste nicht gedrückt: Ankopplung über einen Kondensator; GD-Taste gedrückt: Eingang vom Signal getrennt, Verstärker an Masse geschaltet.
③ <b>X-Y</b> (Drucktaste)	Umschaltung auf XY-Betrieb. Zuführung der horiz. Ablenkspannung über den Eingang von Kanal II. <b>Achtung! Bei fehlender Ablenkung Einbrenngefahr.</b>	②③ <b>INPUT CH. I</b> (BNC-Buchse)	Signaleingang Kanal I. Eingangsimpedanz 1MΩ  25pF.
④ <b>X-MAG. x10</b> (Drucktaste)	Dehnung der X-Achse um den Faktor 10. Max. Auflösung 5ns/cm.	②④ <b>VOLTS/DIV.</b> (10stufig. Drehschalter)	Eingangsteiler für Kanal I. Bestimmt die Y-Ablenkoeffizienten in 1-2-5 Schritten und gibt den Umrechnungsfaktor an (V/cm, mV/cm).
⑤ <b>HOLD OFF</b> (Drehknopf)	Verlängerung der Holdoff-Zeit zwischen den Ablenkperioden. Grundstellung = Linksanschlag.	②⑤ <b>INV. CH. I</b> (Drucktaste)	Invertierung der Signaldarstellung von Kanal I. In Verbindung mit gedrückter ADD-Taste = Differenzdarstellung.
⑥ <b>AUTO/NORM</b> (Drucktaste)	Taste nicht gedrückt: Zeitlinie auch ohne Signal sichtbar, Triggerung autom. Taste gedrückt: Zeitlinie nur mit Signal, Normaltriggerung mit LEVEL	②⑥ <b>VAR. GAIN</b> (Drehknopf)	Feineinstellung der Y-Amplitude (Kanal I). Vermindert die Verstärkung max. um den Faktor 2,5. Kalibrierung am Rechtsanschlag (Pfeil nach rechts zeigend).
⑦ <b>TRIG. SEL.</b> (Drucktaster) AC-DC-HF-LF---TV (LED-Anzeigen)	Wahl der Triggerankopplung: <b>AC:</b> 10Hz–40MHz. <b>DC:</b> 0–40MHz. <b>HF:</b> 40kHz–130MHz. <b>LF:</b> 0–1kHz. <b>~:</b> Triggerung mit Netzfrequenz. <b>TV:</b> Triggerung für Bild und Zeile. LED zeigt Triggerkopplung an.	②⑦ <b>Y MAG. x5</b> (Drucktaste)	Erhöht die Y-Verstärkung von Kanal I um den Faktor 5 (max. 1mV/cm).
<b>TRIG.</b> (LED-Anzeige)	<b>TR:</b> Anzeige leuchtet, wenn Zeitbasis getriggert wird.	②⑧ <b>CH I/II-TRIG. I/II</b> (Drucktaste)	Keine Taste gedrückt: Kanal I-Betrieb und Triggerung von Kanal I. Taste gedrückt: Kanal II-Betrieb und Triggerung von Kanal II. (Triggerumschaltung bei DUAL-Betr.).
⑧ <b>TIME/DIV.</b> (23stufiger Drehschalter)	Bestimmt Zeitkoeffizienten. Analog: 0.05µs/cm-1s/cm, Digital: 5µs/cm bis 50s/cm.	②⑨ <b>DUAL</b> (Drucktaste)	Taste nicht gedrückt: Einkanalbetrieb. Taste DUAL gedrückt: Zweikanalbetrieb mit alternierender Umschaltung. DUAL und ADD gedrückt: Zweikanalbetrieb mit Chopper-Umschaltung.
⑨ Variable Zeitbasiseinstellung (Drehknopf)	Feineinstellung der Zeitbasis. Vermindert Zeitablenkgeschwindigkeit max. 2,5fach (nur im Analogbetrieb). Cal.-Stellung am Rechtsanschlag (Pfeil nach rechts).	<b>CHOP.</b>	③⑩ <b>ADD</b> (Drucktaste)
⑩ <b>TLD</b> (Drucktaste)	Schaltet die Triggerpegel-Anzeige ein.		ADD allein gedrückt: Algebr. Addition. In Kombination mit INV. Tasten: Differenzbetrieb.
⑪ <b>SLOPE +/-</b> (Drucktaste)	Wahl der Triggerflanke. Taste nicht gedrückt: ansteigend, Taste gedrückt: fallend.	③① <b>OVERSCAN</b> (LED-Anzeigen)	Richtungsanzeigen. Leuchten auf, wenn der Strahl den Bildschirm in vertikaler Richtung verläßt.
⑫ <b>LEVEL</b> (Drehknopf)	Trigger-Pegeleinstellung.	③② <b>Y MAG. x5</b> (Drucktaste)	Erhöht die Y-Verstärkung von Kanal II um den Faktor 5 (max. 1mV/cm).
⑬ <b>TRIG. INP.</b> (BNC-Buchse)	Eingang für externes Triggersignal. Taste TRIG. EXT. gedrückt.	③③ <b>VOLTS/DIV.</b> (10stufig. Drehschalter)	Eingangsteiler Kanal II. Bestimmt die Y-Ablenkoeffizienten in 1-2-5 Schritten und gibt den Umrechnungsfaktor an (V/cm, mV/cm).
<b>TRIG. EXT.</b> (Drucktaste)	Umschaltung auf externe Triggerung. Signalzuführung über BNC-Buchse TRIG. INP.	③④ <b>INV. CH. II</b> (Drucktaste)	Invertierung von Kanal II. In Verbindung mit gedrückter ADD-Taste = Differenzdarstellung.
⑭ <b>INTENS.</b> (Drehknopf)	Helligkeitseinstellung für den Kathodenstrahl.	③⑤ <b>VAR. GAIN</b> (Drehknopf)	Feineinstellung der Y-Amplitude (Kanal II).
⑮ <b>TR</b> Trimpotentiometer (Einstellung mit Schraubenzieher)	Trace Rotation (Strahldrehung). Dient zur Kompensation des Erdmagnetfeldes. Der horizontale Strahl wird damit parallel zum Raster gestellt.	③⑥ <b>INPUT CH. II</b> (BNC-Buchse)	Signaleingang Kanal II und Eingang für Horizontalablenkung im XY-Betrieb.
⑯ <b>FOCUS</b> (Drehknopf)	Schärfereinstellung für den Kathodenstrahl.	③⑦ <b>AC-DC-GD</b> (Drucktasten)	Tasten für die Eingangssignalankopplung von Kanal II. Sonst wie ②②.
⑰ <b>ILLUM.</b> (Drucktaste)	Rasterbeleuchtung Ein/Aus.	③⑧ <b>Y-POS. II</b> (Drehknopf)	Einstellung der vertikalen Position des Strahles für Kanal II. Im XY-Analog-Betrieb außer Funktion.
⑱ <b>GND</b>	Massebuchse		
⑲ <b>0.2V-2V</b>	Ausgänge des Rechteck-Kalibrators 0,2V <sub>ss</sub> und 2V <sub>ss</sub> .		
⑳ <b>CAL. 1kHz/1MHz</b> (Drucktaste)	Frequenz des Kalibrator-Ausgangs. Taste nicht gedrückt: ca. 1kHz, Taste gedrückt: ca. 1MHz.		



### Switching on and initial setting

Connect instrument to power outlet, depress red POWER button. LED indicates operating condition.

**Case, chassis and all measuring terminals are connected to the safety earth conductor (Safety Class I).**

Do not depress any further button. **AC** trigger coupling active.

**AUTO/NORM**-pushbutton in **AUTO** position, CH.I input coupling switch to GD,  
set **TIME/DIV.** switch to 0.2ms/div.

Adjust **INTENS.** control for average brightness.

Center trace on screen using **X-POS.** and **Y-POS.** controls.

Then focus trace using **FOCUS** control.

### Vertical amplifier mode

Channel I: All buttons in the Y section in out position.

Channel II: **CHI/II** button depressed.

Channel I and II: **DUAL** button depressed. Alternate channel switching: **ADD** button in out position.

Signals <1kHz or time coefficient  $\geq 1\text{ms/cm}$ : **ADD** button additional depressed.

Channel I+II or -I+(-II) (sum): depress only **ADD** button.

Channel +I-II or -I+II(difference): depress **ADD** and an **INV.** button.

### Triggering mode

Automatic Triggering: **AUTO/NORM** undepressed in **AUTO** position. Trace always visible.

Normal Triggering: **AUTO/NORM** in **NORM** position (depressed). Trace visible when triggered.

Trigger edge direction: select with **SLOPE +/-** button.

Internal triggering: select channel with **TRIG. I/II(CH. I/II)** button.

External triggering: **EXT.** button depressed; sync. signal ( $0.1V_{pp}$  to  $2V_{pp}$ ) to **TRIG. INP.** socket.

Line triggering: depress **TRIG. SEL.** button until ~ symbol lights.

Select trigger coupling with **TRIG. SEL.** switch (sequence: **AC-DC-HF-LF**). Trigger frequency ranges:

**AC:**  $\geq 10\text{Hz}$  to 40 MHz; **DC:** DC to 40MHz; **HF:** 30Hz to 130MHz; **LF:** DC to 1kHz.

Composite video signal with line or horizontal frequency: **LEVEL** fully counter clockwise.

Composite video signal with frame or vertical frequency: **LEVEL** fully clockwise.

Depress **TRIG. SEL.** until **TV** is indicated.

Select **SLOPE** switch to + (sync. pulse above) or - positions (sync. pulse below).

Pay attention to trigger indicator: **LED** marked **TR** above the trigger coupling indicators.

### Storage mode

Mode selector switch: **STOR.** button.

**STOR. LED** lights continuously in storage mode.

Memory hold condition: Channel I, II, DUAL, ADD or X-Y: **HOLD** button depressed.

Store reference signal(s) with **SAVE REF.** button.

Display reference signal(s) with **DISP. REF.** button depressed.

Set reference signal(s) Y position with **REF.-POS.** (not in X-Y mode).

Single sweep: first **SINGLE** button, after that **RESET** button depressed. **RESET LED** lights at trigger readiness.

**ROLL:** depress ROLL pushbutton. The timebase range is set automatically to **s** (seconds) mode.

### Measurements

Apply test signal to the vertical input connectors of **CH. I** and/or **CH. II**.

Before use, calibrate attenuator probe with built-in square wave generator **CAL.**

Switch input coupling to **AC** or **DC**.

Adjust signal to desired display height with attenuator switch.

Select time coefficient on the **TIME/DIV.** switch.

Incorrect time coefficient setting in storage mode is indicated by the flashing **STOR. LED.**

Set trigger point with **LEVEL** knob for Normal Triggering.

Display trigger marker with **TLD** depressed in **DC** coupling conditions.

Trigger complex or aperiodic signals with longer **HOLD-OFF**-time.

Amplitude measurement with Y fine control at right stop (**CAL.**).

Time measurement with time fine control at right stop (**CAL.**).

Time expansion x10 ( analog and digital) with **X-MAG. x10** button depressed.

Time expansion x5 (only digital) with **X-MAG. STOR. x5** button depressed.

Time expansion x50 (only digital) both **X-MAG. STOR. x5 and x10** buttons depressed.

External horizontal sweep (**X-Y mode**) with **X-Y** button depressed (X input: **CH. II**).

# **HAMEG<sup>®</sup>**

## **Instruments**

**Oscilloscopes**  
**Multimeters**  
**Counters**  
**Frequency**  
**Synthesizers**  
**Generators**  
**R- and LC-**  
**Meters**  
**Spectrum**  
**Analyzers**  
**Power Supplies**  
**Curve Tracers**  
**Time Standards**

### **Germany**

#### **HAMEG GmbH**

Kelsterbacher Str. 15-19  
60528 FRANKFURT am Main  
Tel. (069) 67805-0  
Telefax (069) 6780513

### **France**

#### **HAMEG S.a.r.l**

5-9, av. de la République  
94800-VILLEJUIF  
Tél. (1) 4677 8151  
Telefax (1) 4726 3544

### **Spain**

#### **HAMEG S.L.**

Villarroel 172-174  
08036 BARCELONA  
Teléf. (9) 3 4301597  
Telefax (9) 3 3212201

### **Great Britain**

#### **HAMEG LTD**

74-78 Collingdon Street  
LUTON Bedfordshire LU1 1RX  
Phone (0582) 413174  
Telefax (0582) 456416

### **United States of America**

#### **HAMEG, Inc.**

1939 Plaza Real  
OCEANSIDE, CA 92056  
Phone (619) 630 4080  
Telefax (619) 630 6507

#### **HAMEG, Inc.**

266 East Meadow Avenue  
EAST MEADOW, NY 11554  
Phone (516) 794 4080  
Toll-free (800) 247 1241  
Telefax (516) 794 1855

### **Hong Kong**

#### **HAMEG LTD**

Flat 1, 4/F.  
Crown Industrial Building  
106 How Ming St., Kwun Tong  
Kowloon, Hong Kong  
Phone (852) 2 793 0218  
Telefax (852) 2 763 5236

